



# DP1001 8 mm Proximity Probe Assembly Product Manual

## TABLE OF CONTENTS

• Introduction.....	3
• Product Description.....	3
• Proximity Probe Specifications .....	4
• Proximity Probe Extension Cable Specifications .....	8
• Proximity Probe Driver Specifications .....	9
• Installation .....	11
• Electrical Connections .....	13
• Target Surfaces .....	15
• Setup and Adjustment.....	15
• Operation.....	15
• Troubleshooting.....	16
• Maintenance .....	16
• Warranty and Return Information .....	16



## INTRODUCTION

This document contains information on the operation, installation and maintenance of the DP1001 / DC1001 / DD1001 series of 8 mm proximity probe products.

### 8 mm Proximity Probe Series Overview

The DP1001 / DC1001 / DD1001 proximity probe assembly utilizes an eddy current, producing a negative voltage that is directly proportional to the "gap" distance between the probe and measured surface. The assembly consists of a proximity probe, extension cable and compatible driver. The driver is a three- or four-wire device with connections for power, common, and signal output, and is intended for use with a DC negative voltage power supply. **CTC's PRO proximity probe products are mutually exclusive. PRO proximity probes and drivers must be paired with each other for proper use.**



# PROXIMITY PROBE SPECIFICATIONS

PRO Model: DP1001 Series

\* Note: CTC's PRO proximity probes are only compatible with a PRO driver.

## Environmental

Temperature Range: -31 °F (-35 °C) to 350 °F (177 °C)  
Humidity Range: 0 - 95% relative, non-condensing  
Pressure Rating: Probe tip is designed to withstand a pressure difference from machine to ambient via a Viton® O-ring. If pressure testing is required contact CTC.

## Electrical

\* Note: All specifications acquired through use of a AISI 4140 steel target, 1 in. diameter.

### Linear Range

Calibrated Linear Range: 10 - 90 mils (0.25 mm - 2.30 mm)  
Nominal Output: -1 to -17 V<sub>DC</sub>  
Nominal Sensitivity: -200 mV/mil (-7.87 V/mm)

### Incremental Scale Factor (ISF)

\* Note: When measured over calibrated linear range in increments of 10 mils

32 °F (0 °C) - 113 °F (45 °C)

0.5 Meter System	-200 mV/mil (-7.87 V/mm) ±5%
1 Meter System	-200 mV/mil (-7.87 V/mm) ±5%
5 Meter System	-200 mV/mil (-7.87 V/mm) ±5%
9 Meter System	-200 mV/mil (-7.87 V/mm) ±6.5%

-31 °F (-35 °C) - 248 °F (120 °C)

0.5 Meter System	-200 mV/mil (-7.87 V/mm) ±10%
1 Meter System	-200 mV/mil (-7.87 V/mm) ±10%
5 Meter System	-200 mV/mil (-7.87 V/mm) ±10%
9 Meter System	-200 mV/mil (-7.87 V/mm) ±18%

### Deviation from Best Fit Straight Line (DSL)

\* Note: When measured over calibrated linear range in increments of 10 mils

32 °F (0 °C) - 113 °F (45 °C)

0.5 Meter System	±1.0 mil
1 Meter System	±1.0 mil
5 Meter System	±1.0 mil
9 Meter System	±1.5 mil



-31 °F (-35 °C) - 248 °F (120 °C)

0.5 Meter System                    ±3.0 mil

1 Meter System                     ±3.0 mil

5 Meter System                    ±3.0 mil

9 Meter System                    ±6.0 mil

## Linear Range Deviation Over Temperature

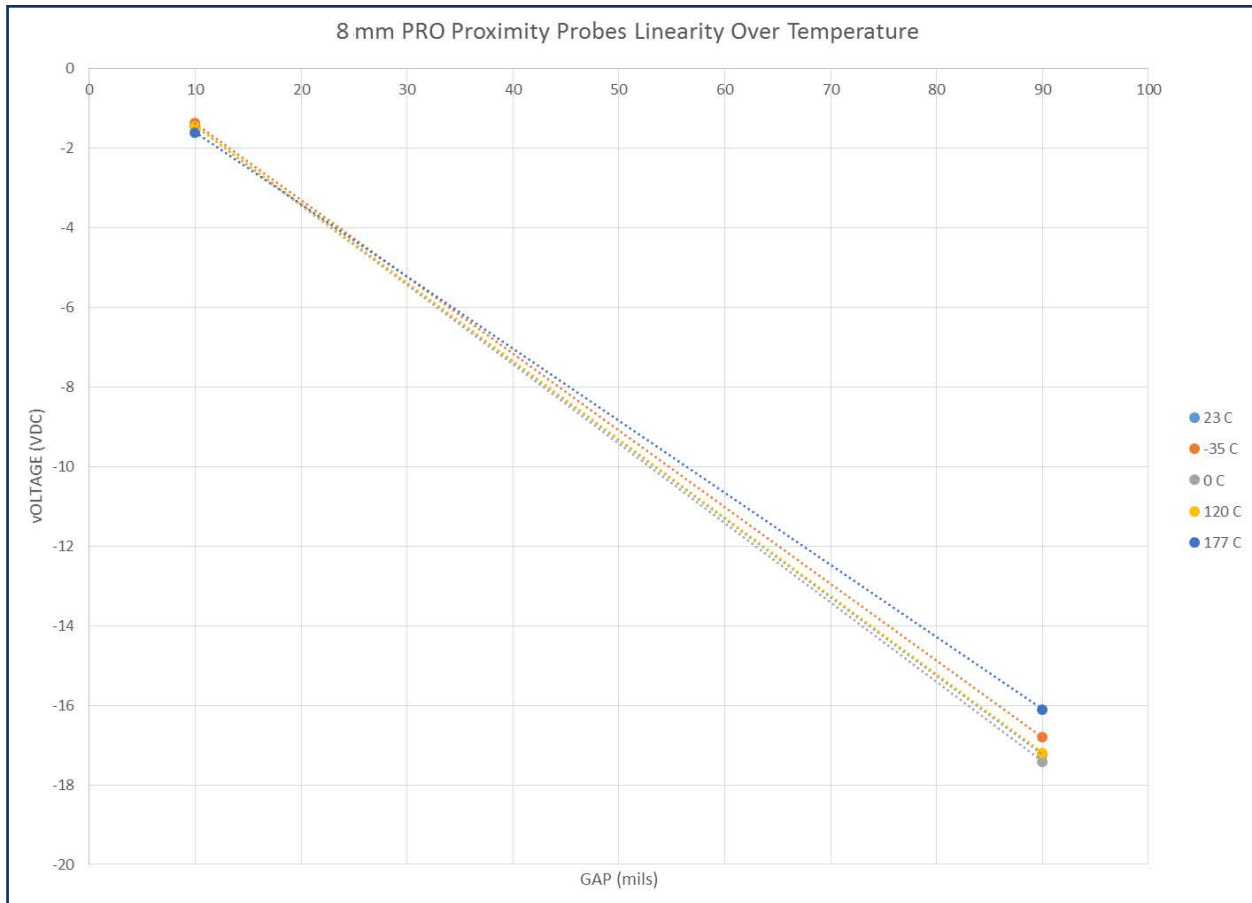

**Figure 1. Linear Range Deviation Over Temperature**

## Physical

### Materials

8 mm Tip: 40% glass-filled PPS (Polyphenylene Sulfide)  
Threaded Case: 316L stainless steel  
Connector Material: 12-32 threaded gold-plated brass with Teflon® insulators

### Weight

Probe: 49 g (0.1 lb) maximum

### Dimensions

Coaxial Cable: FEP (Flourinated Ethylene Propylene)  
Cable Lengths: 0.5, 1.0, 5.0, 9.0 meters

**\* All probes have length tolerance of (+30% / -0%)**

### Mounting Hardware

3/8-24 Standard Case: 5/16 in. wrench flats at rear of probe  
2x 5/8 in. hex nuts for mounting

M10x1 Standard Case: 8 mm wrench flats at rear of probe  
2x 17 mm hex nuts for mounting

3/8-24 Reverse Mount: Integrated 7/16 in. wrench flats at front of probe body

M10x1 Reverse Mount: Integrated 10 mm wrench flats at front of probe body



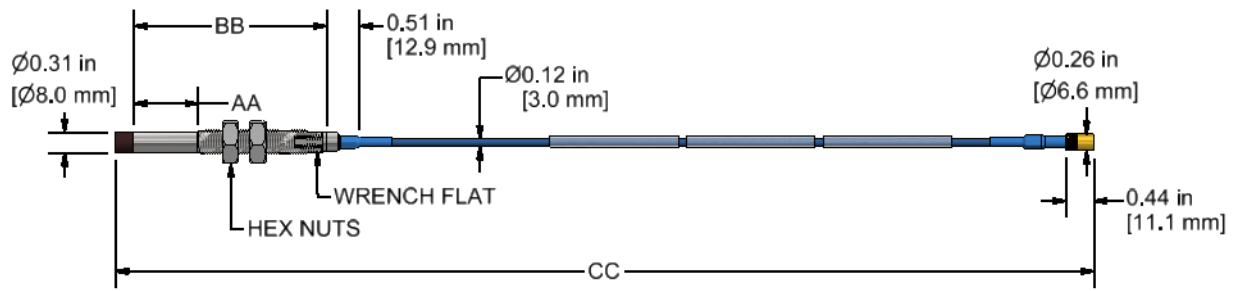

**Figure 2. 8 mm Standard Mount Proximity Probe**

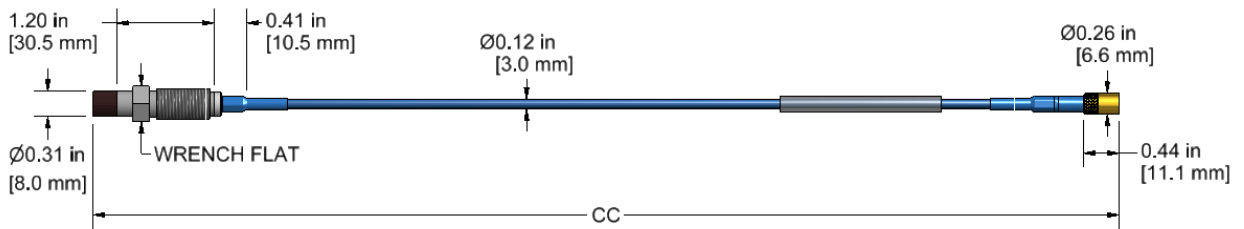

**Figure 3. 8 mm Reverse Mount Proximity Probe**

# PROXIMITY PROBE EXTENSION CABLE SPECIFICATIONS

PRO Model: DC100130 Series

## Environmental

Temperature Range: -31 °F (-35 °C) to 350 °F (177 °C)

Humidity Range: 0 - 95% relative, non-condensing

## Physical

### Materials

Coaxial Cable: FEP (Fluorinated Ethylene Propylene)

Connector Material: 12-32 Secure Lock threaded gold-plated brass with Teflon® insulators

### Weight

Cable: 1 kg (2.2 lb) maximum

### Dimensions

Cable Lengths: 4.0, 4.5, 8.0, 8.5 m nominal

\* All cables have length tolerance of (+30% / -0%)

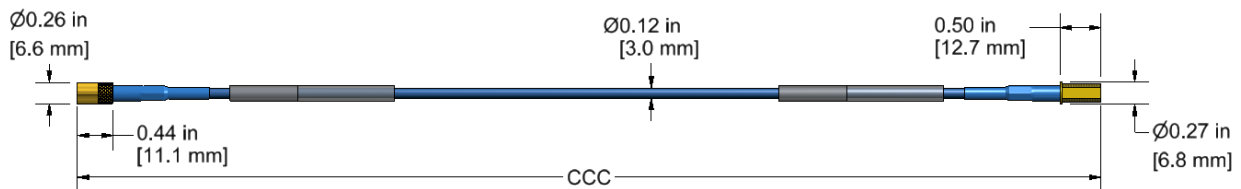

**Figure 4. 8 mm Proximity Probe Extension Cable**



# PROXIMITY PROBE DRIVER SPECIFICATIONS

PRO Model: DD1001 Series

\* Note: CTC's PRO proximity probe drivers are only compatible with a PRO probe.

## Environmental

Temperature Range: -31 °F (-35 °C) - 185 °F (85 °C)

Humidity Range: 0 - 95% relative, non-condensing

## Electrical

\* Note: All specifications acquired through use of a AISI 4140 steel target, 1 in. diameter

## Linear Range

Calibrated Linear Range: 10 - 90 mils (0.25 mm - 2.30 mm)

Nominal Output: -1 to -17 V<sub>DC</sub>

Nominal Sensitivity: -200 mV/mil (-7.87 V/mm)

Resolution: 0.5 microns

## Incremental Scale Factor (ISF)

\* Note: When measured over calibrated linear range in increments of 10 mils

32 °F (0 °C) - 113 °F (45 °C)

0.5 Meter System -200 mV/mil (-7.87 V/mm) ±5%

1 Meter System -200 mV/mil (-7.87 V/mm) ±5%

5 Meter System -200 mV/mil (-7.87 V/mm) ±5%

9 Meter System -200 mV/mil (-7.87 V/mm) ±6.5%

-31 °F (0 °C) - 185 °F (85 °C)

0.5 Meter System -200 mV/mil (-7.87 V/mm) ±10%

1 Meter System -200 mV/mil (-7.87 V/mm) ±10%

5 Meter System -200 mV/mil (-7.87 V/mm) ±10%

9 Meter System -200 mV/mil (-7.87 V/mm) ±18%

## Deviation from Best Fit Straight Line (DSL)

\* Note: When measured over calibrated linear range in increments of 10 mils

32 °F (0 °C) - 113 °F (45 °C)

0.5 Meter System ±1.0 mil

1 Meter System ±1.0 mil

5 Meter System ±1.0 mil

9 Meter System ±1.5 mil

-31 °F (0 °C) - 185 °F (85 °C)

0.5 Meter System ±3.0 mil

1 Meter System ±3.0 mil

5 Meter System ±3.0 mil

9 Meter System ±6.0 mil



## Operating Power

Input Voltage: -17 to -30 V<sub>DC</sub>  
Power Consumption: 0.81W maximum

\* Note: The driver is protected against reversed polarity.

## Isolation

Case Isolation: Isolation from all connections

## Physical

### Materials

Case: Anodized/powder coated aluminum  
Panel/DIN Mount Hardware: Anodized/powder coated aluminum  
Prox Connector: 12-32 threaded gold-plated brass with Teflon® insulators  
BNC Connector: Polyester housing, gold-plated center contact, polymethylpentene dielectric, zinc or nickel plated shell  
Terminal Block: Polyamide

## Weight

Driver: 0.24 kg (0.53 lb) maximum

## Mounting

DIN Rail: 35 mm standard DIN rail  
Panel: 2.0 in. x 2.0 in. panel mount hole pattern

\* Note: Mounting screws not included

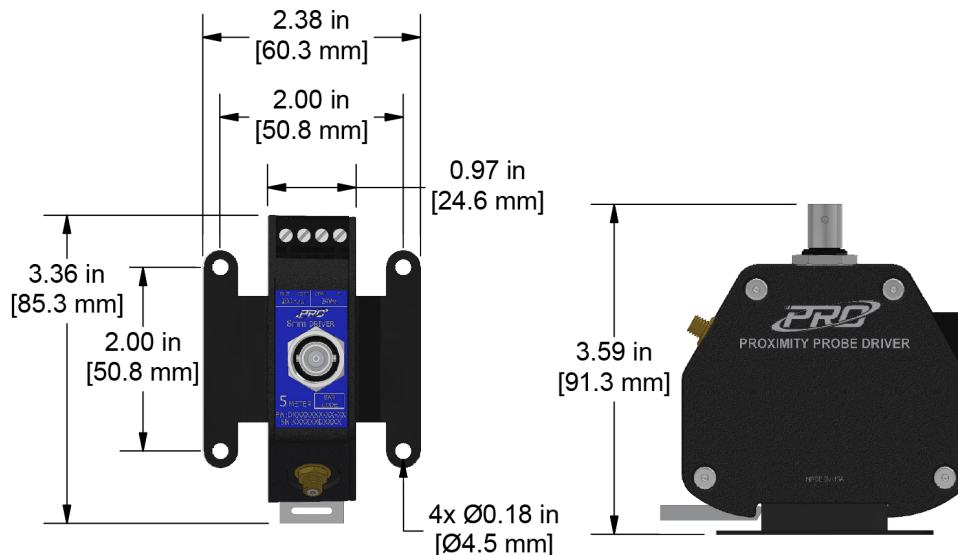

**Figure 5. 8 mm Proximity Probe Driver**

## INSTALLATION INFORMATION

For most applications, the driver is recommended to be mounted in a protective housing. More than one driver may share a single housing/enclosure to simplify installation. CTC offers an extensive line of probe driver enclosures in the PXE series. The drivers are typically DIN rail mounted in the enclosure. Connection to the probe is established when the integral cabling of a proximity probe or an extension cable is attached to the driver's probe connector. Excess proximity probe cabling should be coiled up inside the housing/enclosure. **Do not cut any cable in a probe system. Doing so will affect system accuracy.**

**Note: Only PRO DP series and DC series proximity products should be used for the PRO DD series drivers.**

All connector connections should be tight and secure. Snug the connector screw collar, applying 5 in.-lbs (0.6 N-m) of torque.

**Note: Do not overtighten the probe cable connection. Too much torque may cause damage. Do not exceed a torque of 8 in.-lbs (0.9 N-m). Probe connectors must not touch any machine metal parts. Take proper steps to isolate connectors from metal surfaces. Connector protectors are available upon request.**

Probes are provided with a threaded stainless steel case. These can be mounted directly through the machine housing via a threaded hole. When installing this way, give the proper clearance of 1.5 times the tip diameter around the probe tip (e.g., 1.5 x 8 mm tip diameter = 12 mm clearance). Refer to the figure below.

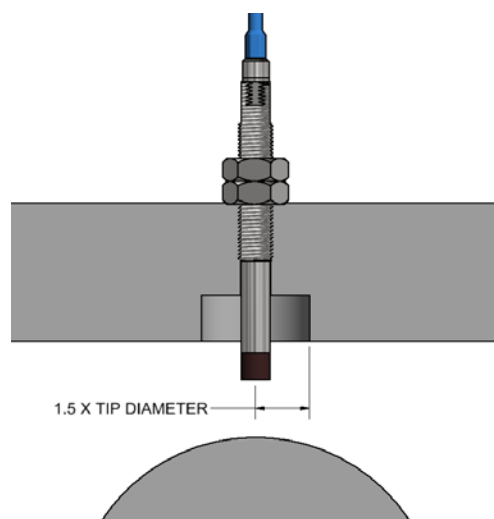

**Figure 6. Probe Tip Clearance**

Standard mounting blocks and bushings are also available. Mounting blocks are available in anodized aluminum or phenolic material, and all bushings are stainless steel.



**Figure 7. Clamping Aluminum Mounting Block**



**Figure 8. Stainless Steel Mounting Bushings**

## Electrical Connections

The DP100180 Probe Driver utilizes eddy current principles to produce a linear negative voltage output proportional to the displacement between the probe tip and the measured surface. The driver is a three-wire system that adheres to API670 standards with connections for power, common, and signal output.

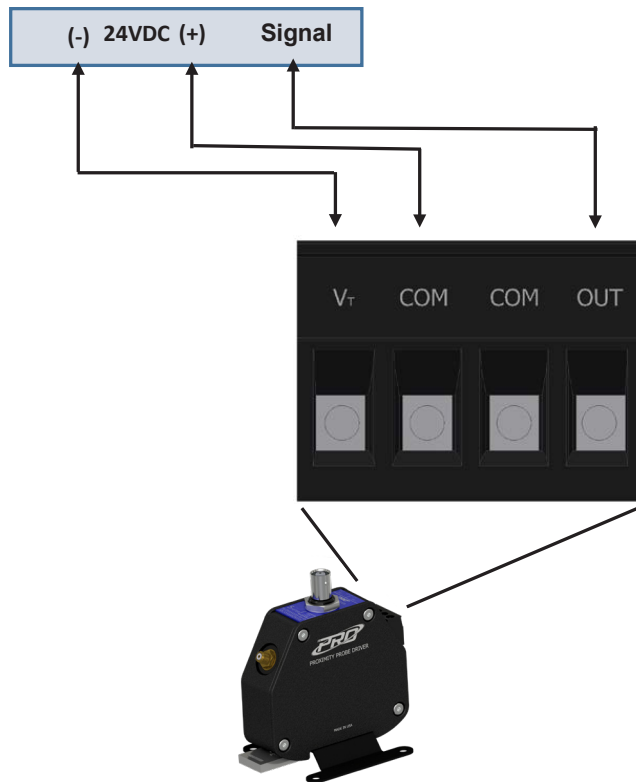

**Figure 9. Three Wire Connection**

**Note: Wiring a power supply between the two COM terminals will damage the driver.**

The DD100170, DD100190, and DD100191 Series Proximity Probe products are four-wire devices with connections for loop power, common, and dynamic signal output. The "70" Series 4-20mA loop is directly proportional to the displacement gap between the probe tip and the measured surface. The "90" and "91" Series 4-20mA loop output is directly proportional to the selectable configured full-scale range.

The driver has four terminal connections: "-", "+", COM, and OUT. The -24 Vdc power is connected to "-" and "+" terminals.

The COM (signal common or ground) terminal is isolated from the driver case. COM is not directly connected to the probe cable connectors.

The OUT terminal is the output signal connection. It is a negative voltage output, with the voltage moving more negatively (higher in magnitude) as the gap between the probe and the machine shaft increases. COM is used for the output as well.

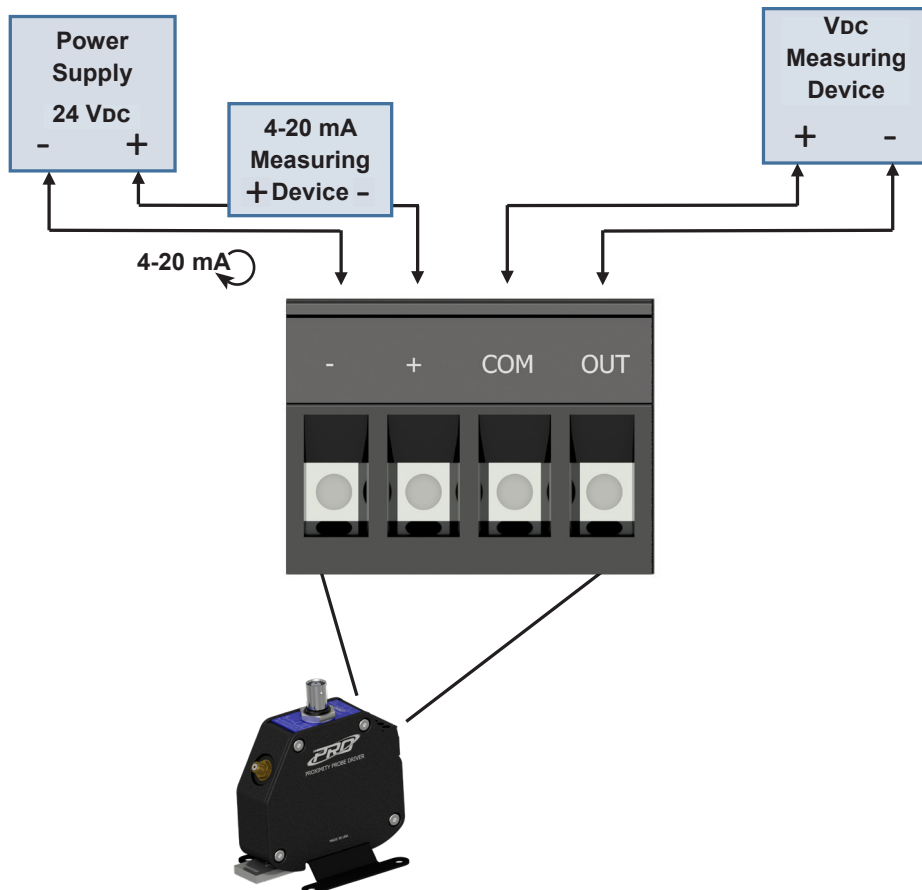

**Figure 10. Four Wire Connection**

**Note: Wiring a power supply between the "-" and COM terminals will damage the driver.**

## Target Surfaces

The target material directly affects the output from the proximity probe system. Drivers can be calibrated for many different target materials. If the target material differs from the material the driver is calibrated to, the output will become non-linear. Please see the complete list of compatible materials at [ctconline.com](http://ctconline.com).

For vibration monitoring of rotating shafts, the observed surface must have a roughness not to exceed 32  $\mu\text{in}$ . (< 1 micron) and must be concentric. False vibration readings will result if the surface is rough or has discontinuities or excessive mechanical run-out. The target area should be at the circumference of a shaft and perpendicular to the probe tip to ensure measurement accuracy.

Linear range may be reduced if the target/shaft diameter < 6 in.

**Note: Shaft diameters should be uniform in the target area and free of keyways (unless performing phase analysis), oil slingers, or mechanical damage.**

## Setup and Adjustment

When all connections to the driver have been made and the probe is in place, apply power to the system. For applications where the only data of interest is vibration level, where measuring the gap is unnecessary, the voltage at the OUT (signal output) terminal, relative to the COM (common) terminal, should be  $-9.0 \pm 5 \text{ V}$  for a mid-range gap of 50 mils. Adjust the probe until this reading is obtained. For applications where the actual gap needs to be measured, adjust the probe until a reading is obtained that reflects the desired initial gap setting.

## OPERATION

A PRO DP Probe Assembly operates in combination with a PRO DD Probe Driver. The driver outputs a signal proportional to the gap between the probe tip and the target. The average gap corresponds to the DC component of the output. Vibration is measured by monitoring the DC variation of the signal simulating an AC component. All drivers have the same 13 V output span. The output sensitivity of the 8 mm driver is  $-200 \text{ mV/mil}$ .



## TROUBLESHOOTING

<b>Problem</b>	<b>Recommended Action</b>
-05 to -0.6 Vbc signal output	Check probe cable/extension cable connection to driver
No signal output	Check power supply

## MAINTENANCE

There are no customer replaceable parts on the proximity probe driver. Once the proximity probe assembly has been installed, minimal maintenance will be required. Basic visual checks should be made periodically to ensure integrity and proper function. It is designed to provide trouble-free continuous service under normal operating conditions. Should the instrument require repair, visit [ctconline.com](http://ctconline.com) for a return material authorization.

## WARRANTY AND REFUND

Please visit [www.ctconline.com](http://www.ctconline.com) to view a complete recapitulation of our warranty and refund policies.

## CONTACT INFORMATION

Connection Technology Center, Inc. (CTC)

7939 Rae Blvd.

Victor, NY 14564

1.585.924.5900

[sales@ctconline.com](mailto:sales@ctconline.com)

[www.ctconline.com](http://www.ctconline.com)

