



**VIBRATION ANALYSIS HARDWARE**



**TCT301 Series Termination Box  
1 Triaxial Sensor Input  
Product Manual**

## TABLE OF CONTENTS

- Introduction.....3
- Product Description.....3
- Product Dimensions.....4
- Mounting Instructions.....5
- Conduit Entry .....6
- Grounding.....7
- Sensor Installation .....9
- Post Installation Testing ..... 12
- Maintenance ..... 13
- Warranty and Refund Information..... 14



## INTRODUCTION

CTC termination box solutions allow for the monitoring of remotely-mounted vibration sensors, which would otherwise be restricted to human access due to safety considerations.

### **TCT301 Series Termination Box Overview: *One triaxial sensor input (three measurement channels), polycarbonate enclosure***

The TCT301 Termination Boxes are a common cable termination point for bringing compatible cables for triaxial sensors into a termination box for routine data collection with portable data collectors. A cover featuring four self-tapping screws allows the box to be sealed from the elements.



# PRODUCT DIMENSIONS

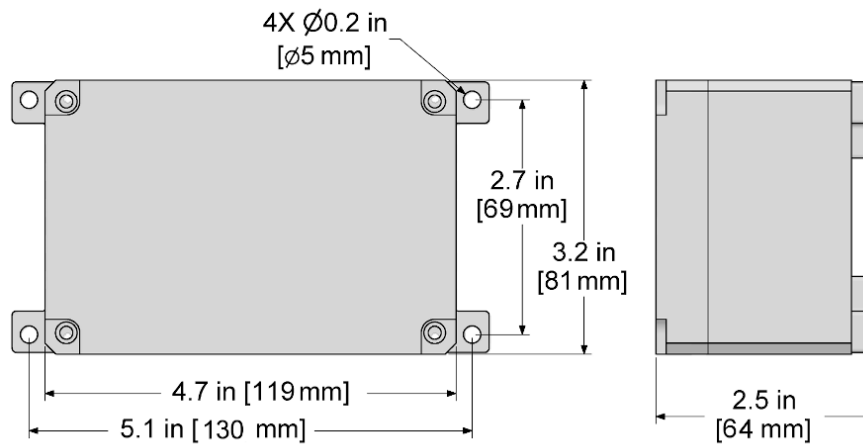

Side View

Rear View

**Figure 1. Dimensions**

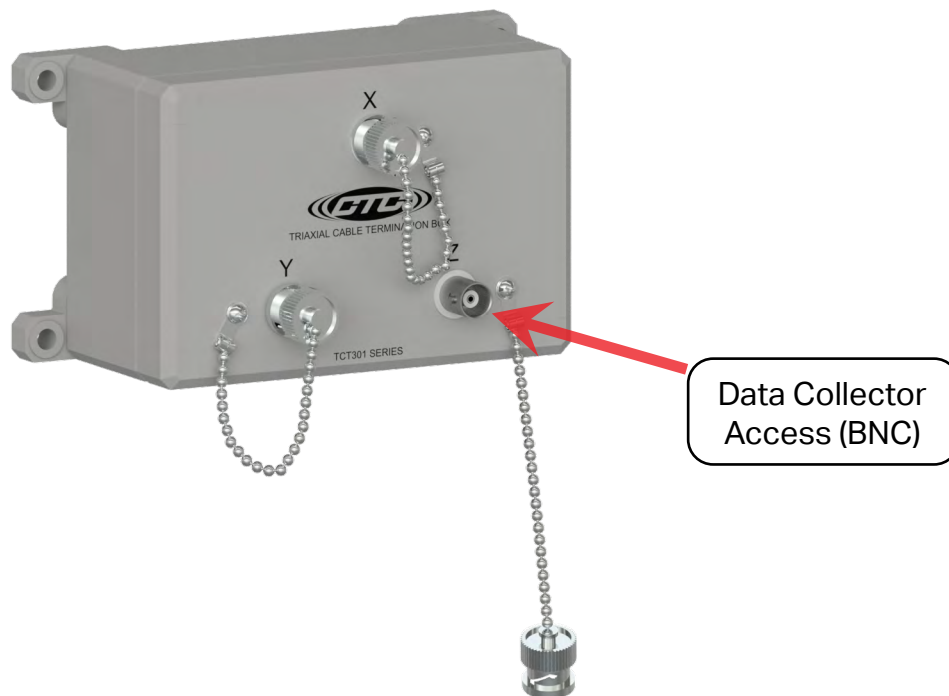

**Figure 2. Diagram**

## MOUNTING INSTRUCTIONS

Molded mounting brackets are included on the enclosure. Wall anchoring screws are not included.

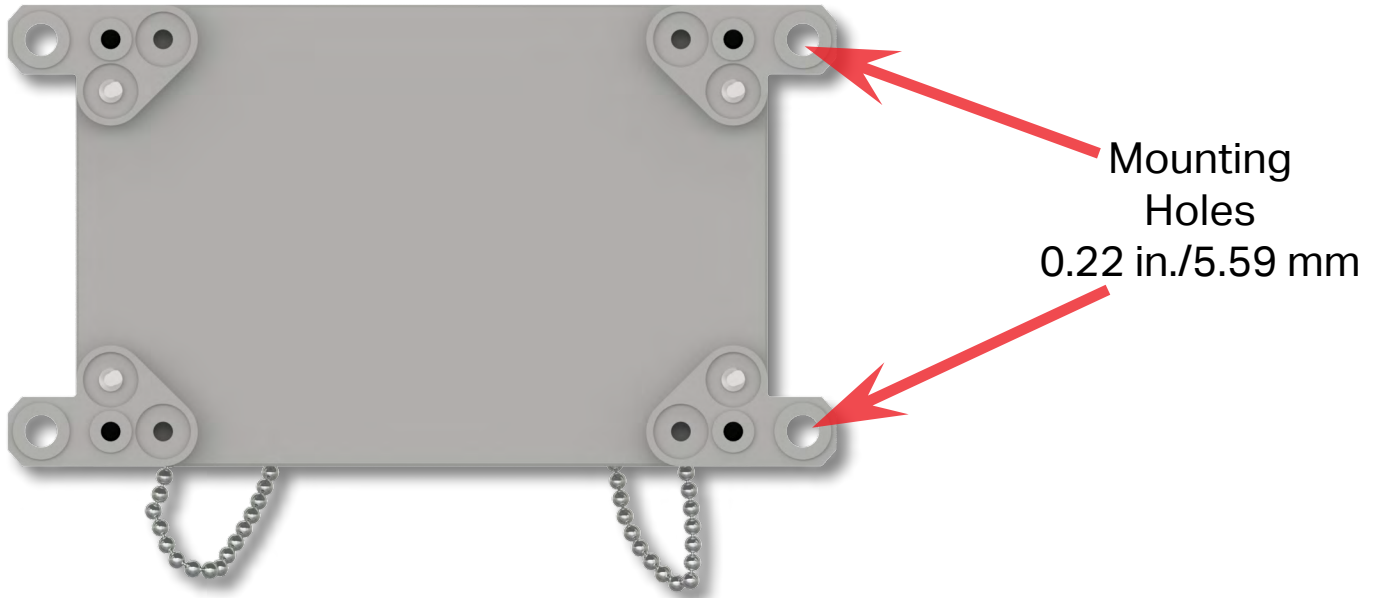

***Figure 3. Cable Termination Box Rear View***

## CONDUIT ENTRY

If you have purchased an enclosure without cable entries provided, you should add your own entry prior to mounting the termination box. CTC does not recommend putting holes in the top of the enclosure as it will cause restricted access to the wire termination connection points and also allow possible moisture ingress.

**Note:** To prevent a buildup of condensation inside the enclosure, provide drainage by drilling a hole in the lowest point of the conduit.

**Correct**

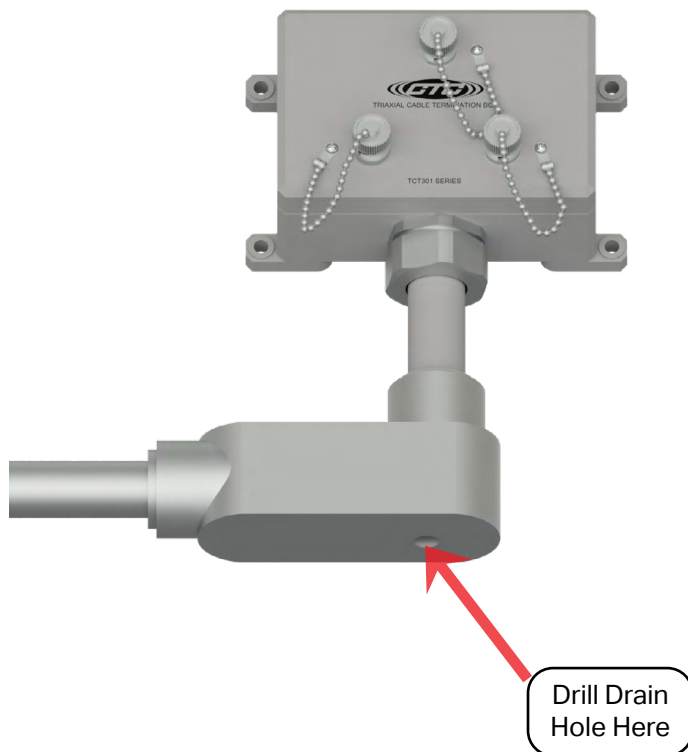

**Incorrect**

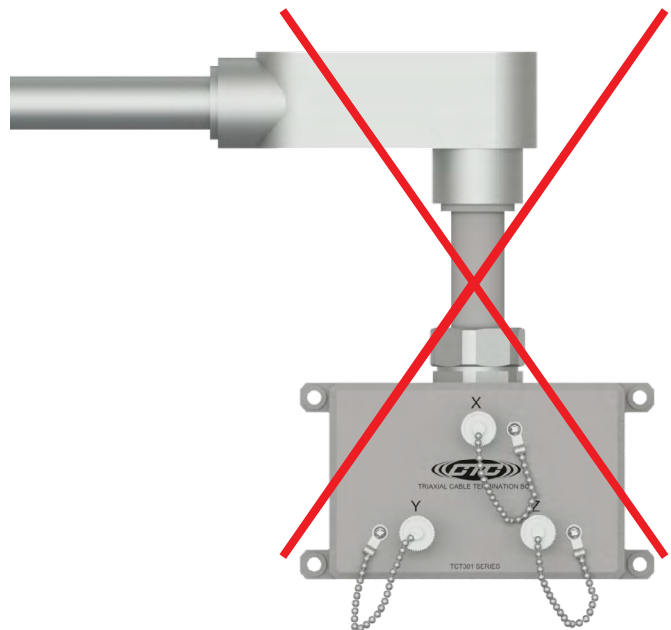

**Figure 4. Conduit Entry for Termination Box**

## GROUNDING

Optional grounding is available on the TCT301 Series. Select the “with ground lug” option (TCT301G) when ordering if external grounding is desired.

### *A. Mounting to Earth Ground*

When mounting TCT301G Series Termination Boxes to earth ground (such as an I-Beam), mount the shield ground wire using a mounting bolt through one of the mounting brackets on the enclosure. See Figure 5 below.

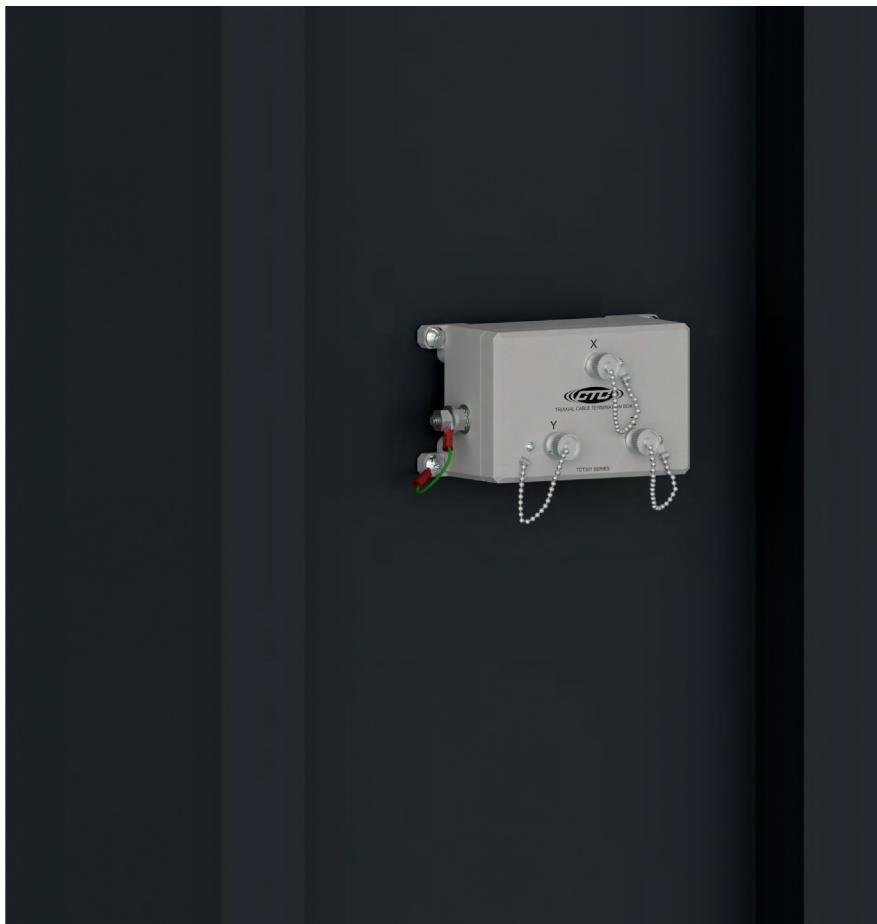
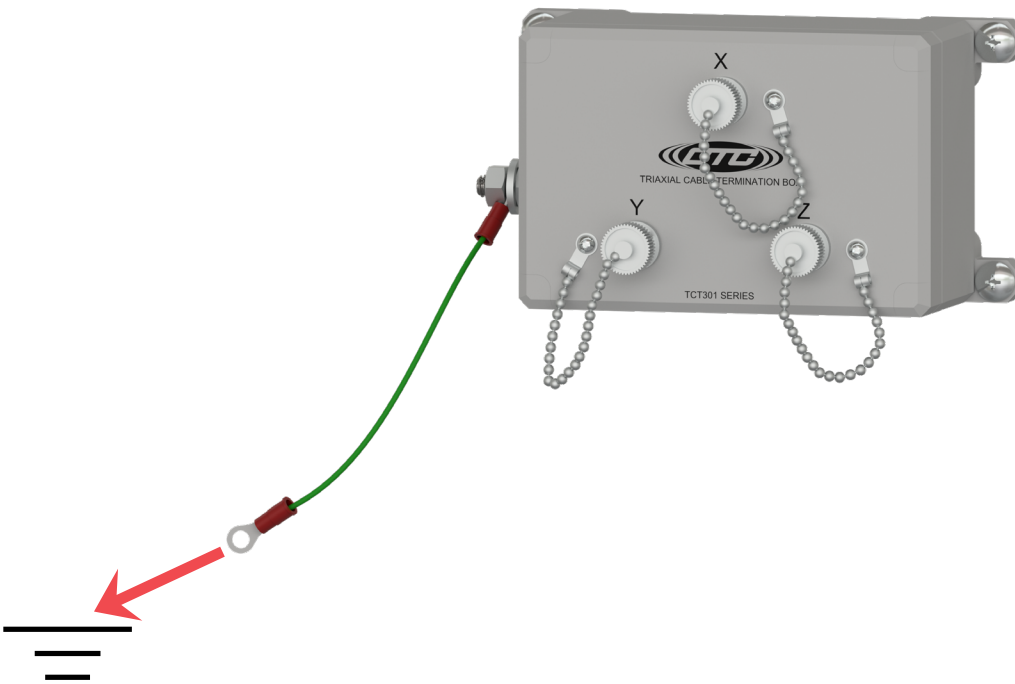

***Figure 5. Cable Termination Box Earth Ground***

# GROUNDING

## B. Mounting to Non-Grounded Structure

When mounting the TCT301G to a non-grounded structure, ensure the shield ground wire or customer-supplied ground wire is tied to a source of earth ground.



**Figure 6. Ground Wire Placement**

# SENSOR INSTALLATION

## Installation of Sensors/Signal Input Cable

1. Feed blunt-cut end through the cable entry at the bottom of the enclosure.  
**Note:** It is recommended that cables are marked on both ends.

For cord grip cable entry, take off the cord grip cover with bushing and run cable through it then into the enclosure, hand-tighten cord grip cover to base to prevent damage of cord grip.



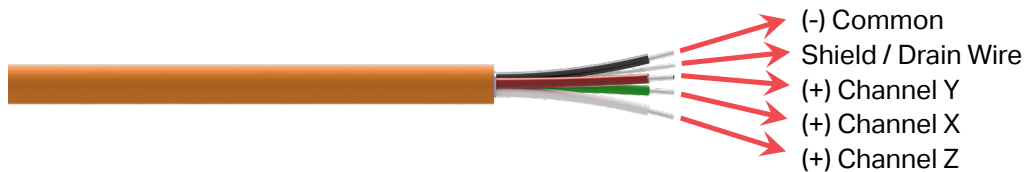

**Figure 7. Front View**



**Figure 8. Bottom View with Cord Grips Installed**

1. Strip outer jacket of cable back 1¼ in. and remove all of the shielding.
2. Separate the internal wires from the shield.
3. Strip red and black insulation back ¼ in.



**Figure 9. Stripped Wire**

4. While viewing the rear of the panel, locate the appropriate channel. Using a mini flathead screwdriver, loosen the three screws for the channel and insert the wires into the termination block. Orientation is as follows:
  - a. Green insulated conductor wire (X) is connected to the first channel used.
  - b. Red insulated conductor wire (Y) is connected to the second channel.
  - c. White insulated conductor wire (Z) is connected to the third channel used.
  - d. Black insulated conductor wire is connected to (-) and must be applied to each channel.
  - e. Shield drain wire is connected to ground (GND) and needs only one termination. Tighten the screw on each wire to hold it in place.

# SENSOR INSTALLATION

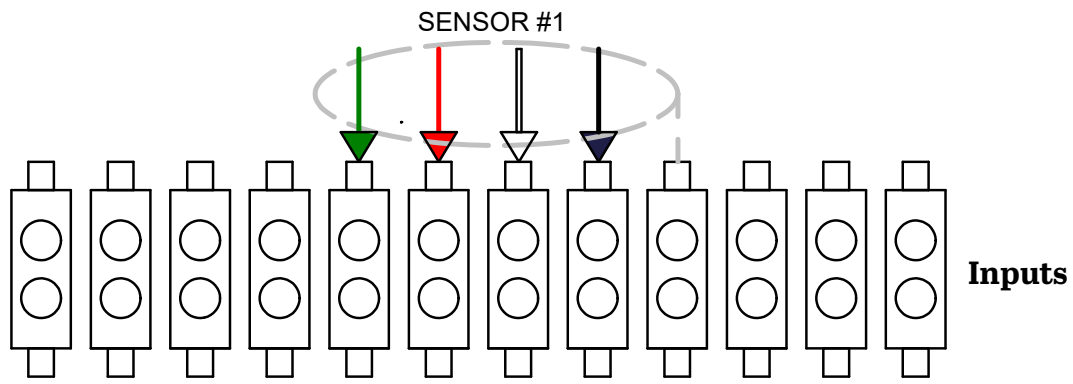

Sensor Inputs  
Green = Positive X Axis  
Red = Positive Y Axis  
White = Positive Z Axis  
Black = Common  
Grey = Shield (Ground)

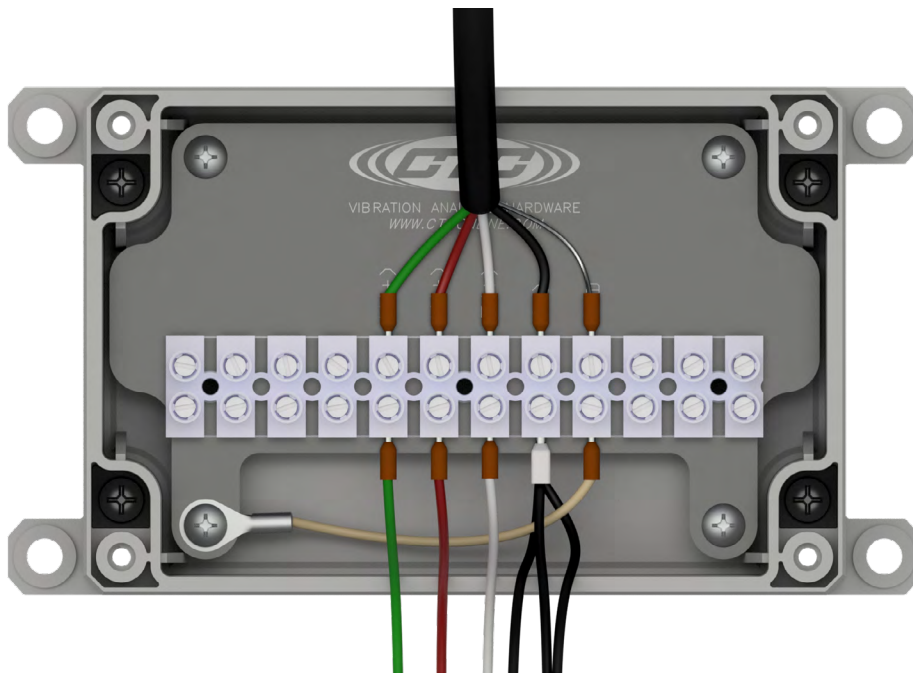

**Figure 10. Field Wiring for Four-Conductor Triaxial Sensor Inputs**

## POST INSTALLATION TESTING

The TM1018 Accelerometer Verification Meter can be used to verify cable conductivity, sensor location and proper wiring connections. The Verification Meter will indicate if the sensor, cable and/or junction box is in working condition. It will also confirm bias voltage of the accelerometer, which will inform you of the operation of the internal accelerometer amplifier.



**Figure 12. TM1018 Accelerometer Verification Meter**

### Testing Method:

1. Utilizing two personnel, Person A will be located at the termination box, while Person B will be located at the measurement location.
2. Once positioned, Person A will connect the TM1018 to the data collector output to the termination box and turn the Channel Selector to the channel that corresponds to the referenced measurement. Person A should observe a "NORMAL" LED reading.
3. Person B disconnects the cable from the accelerometer, and the TM1018 should respond with an "OPEN" LED. Reconnect the cable to the accelerometer, and the TM1018 should respond with a "NORMAL" LED.
4. Repeat for each measurement location to verify that accelerometer location is properly identified at the termination box.

## POST INSTALLATION TESTING

The following LED Readout indicates the circuit integrity:

1. Green LED: Normal. Indicates proper connection and an output bias will be given, indicating the health of the sensor (4 – 16 V indicates a healthy accelerometer).
2. Yellow LED: Open Circuit. Indicates one of the following:
  - a. Cable connector is not connected to accelerometer.
  - b. Cable is open circuit (broken or not connected at one end).
  - c. Accelerometer is not functioning correctly.
3. Red LED: Short Circuit. Indicates one of the following:
  - a. Water or contamination in the connector.
  - b. Reverse wiring ((+) and (-) leads are reversed) at terminal block inputs of the termination box.
  - c. Wires in termination box or cable connector (+) & (-) are touching.

## MAINTENANCE

Once the system has been installed, it requires minimal maintenance. Basic checks to ensure system integrity should be made periodically.

Visual inspection should include examinations for the following:

1. No Visible electrical burns or smoke inside the enclosure.
2. Enclosure hinges are free from rust and securely latched.
3. No moisture or condensation is present inside the enclosure.



## **WARRANTY & REFUND**

Please visit [www.ctconline.com](http://www.ctconline.com) to view a complete recapitulation of our warranty and refund policies.

## **CONTACT INFORMATION**

Connection Technology Center, Inc. (CTC)

7939 Rae Blvd.

Victor, NY 14564

1.585.924.5900

[sales@ctconline.com](mailto:sales@ctconline.com)

[www.ctconline.com](http://www.ctconline.com)

