



VIBRATION ANALYSIS HARDWARE



**MMX1000 Series Modular MAXX Box
3-12 Channel
Product Manual**

TABLE OF CONTENTS

- Introduction.....3
- Product Description.....3
- Product Dimensions & Diagram.....4
- Mounting Instructions.....5
- Conduit Entry6
- Grounding.....7
- Installation of Sensor/Signal Input Cable.....8
- Post Installation Testing 11
- Warranty & Return Information 13



INTRODUCTION

CTC modular MAXX box solutions allow for the monitoring of remotely mounted vibration sensors, which would otherwise be restricted to human access due to safety considerations.

MMX1000 Series Modular MAXX Box Overview: 3-12 channel boxes, fiberglass enclosure

The MMX1000 3-12 channel enclosure is a common cable termination point for bringing in a variety of sensor applications including single axis, biaxial, triaxial, and dual output (vib/temp) sensors for routine data collection with portable data collectors.

The MMX1000 Series offers convenient three position quick connect terminal blocks for terminating the sensor of your choice.

Note: If continuous output is desired CTC part number JB907-4A will accomplish that application.

Setup of DIP Switches

In addition to the most popular application of single axis sensors, the MMX-MOD3 modules can be setup to provide grouped signals from a Dual Output sensor, triaxial or biaxial style sensor that share the "common" conductor. By adjusting the dip switches, the common connection can be shared between inputs 1 & 2, 2 & 3, for dual outputs and between inputs 1 & 2 for biaxial sensors or 1, 2, & 3 for triaxial sensors. This eliminates the need to insert jumper wires between the different inputs within the module. The switches are displayed further on in this manual. **Note:** All modules are set at "Commons OPEN" at factory.



PRODUCT DIMENSIONS

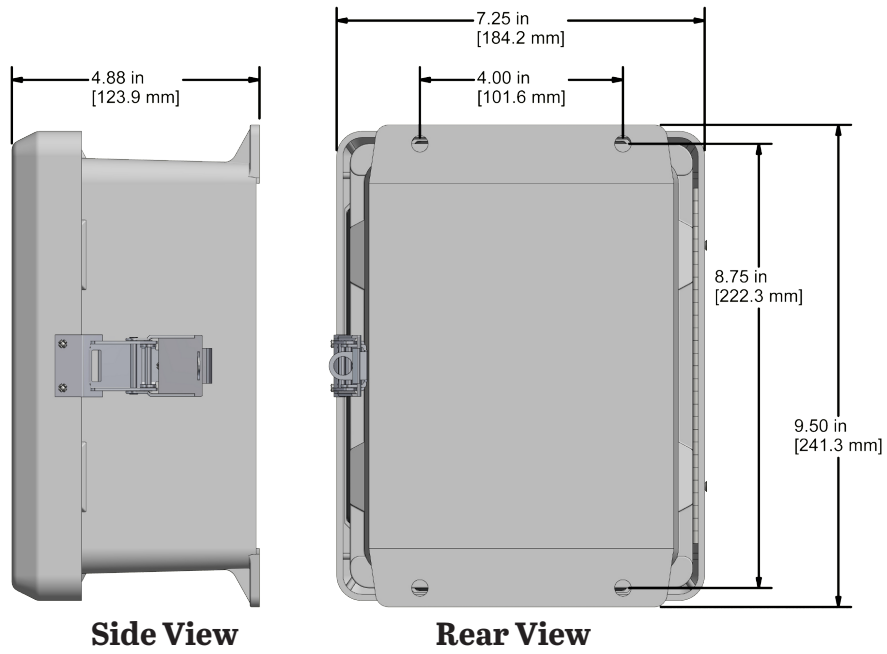

Figure 1. Dimensions

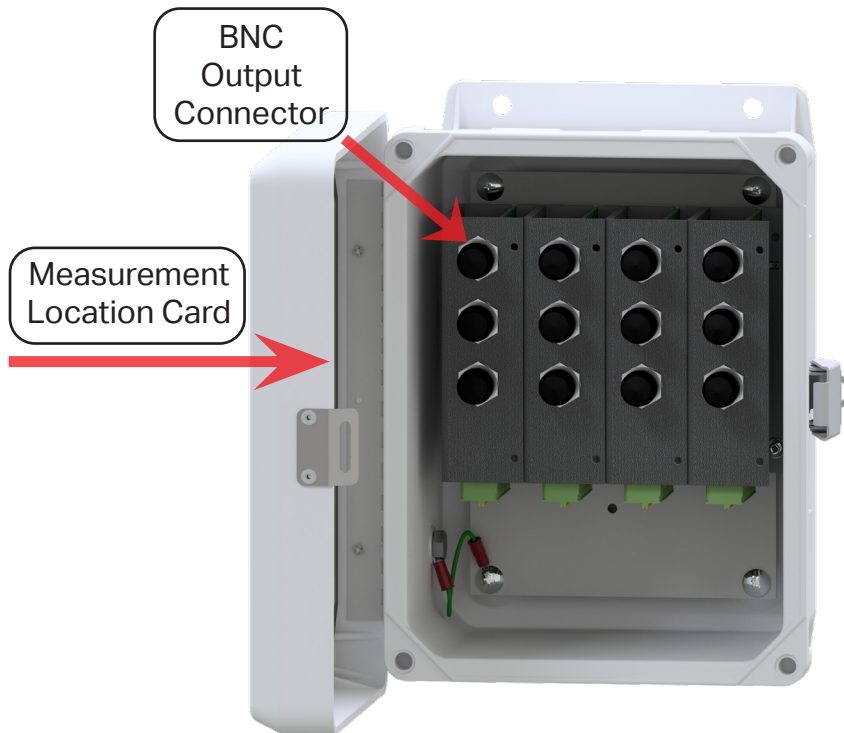

Figure 2. Diagram

MOUNTING INSTRUCTIONS

Note: if you have purchased a modular MAXX box without cable entries provided, you should add your own entry prior to mounting the modular MAXX box. CTC does not recommend putting holes in the top of the enclosure due to access and moisture concerns.

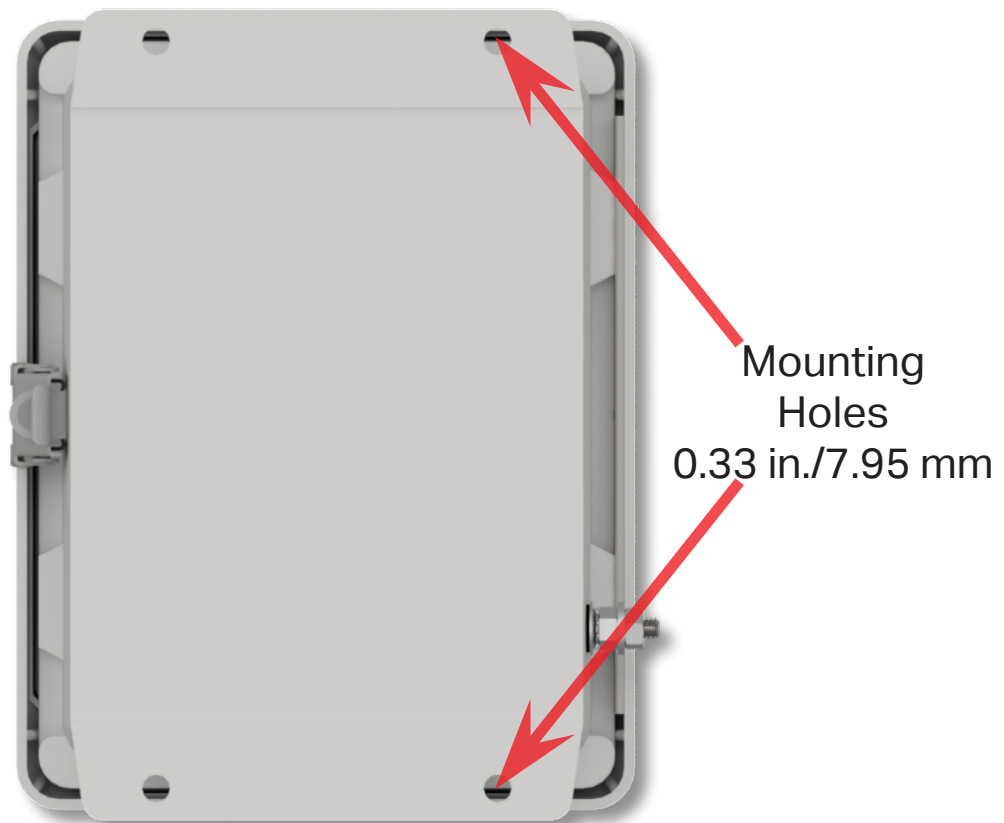

Figure 3. Modular MAXX Box Rear View

CONDUIT ENTRY

If you are running conduit to your enclosure, ensure the conduit cable entry enters from the bottom of the enclosure when mounted.

Note: To ensure moisture will not flow into the enclosure, a hole should be drilled at the lowest point in the conduit to provide drainage for any moisture.

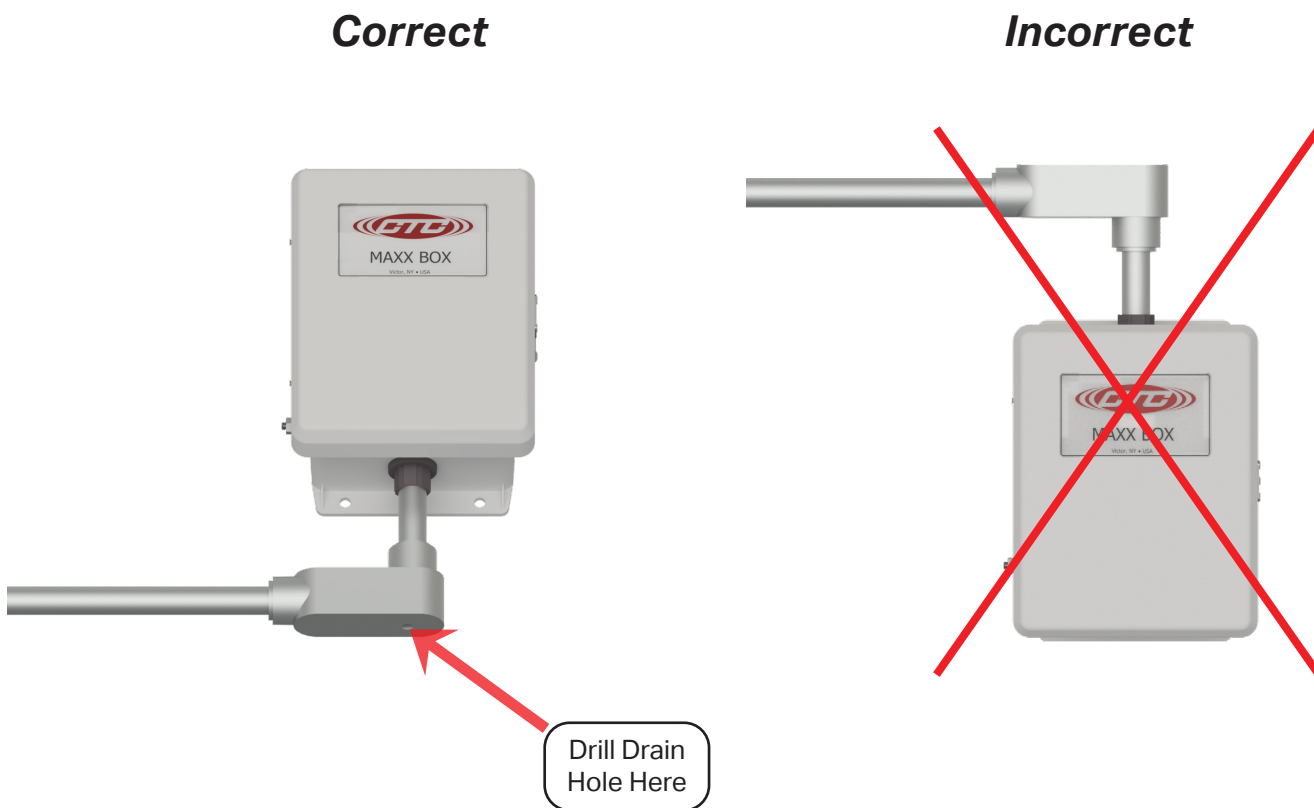

Figure 4. Conduit Entry for Termination Box

GROUNDING

Ensure the shield ground wire on the MMX1000 Series Modular MAXX box is grounded to earth ground.

A. Mounting to Earth Ground

When mounting MMX1000 Series Modular MAXX boxes to earth ground (such as an I-Beam), mount the shield ground wire using a mounting bolt through one of the mounting brackets on the enclosure.



Figure 5. Proper Shield Grounding Technique

B. Mounting to non-grounded structure

When mounting the enclosure to a non-grounded structure, ensure the shield ground wire or customer supplied ground wire is tied to a source of earth ground.



Figure 6. Ground Wire Placement

SENSOR INSTALLATION

Installation of sensors/signal input cable

1. Feed blunt end through the cable entry at the bottom of the enclosure.
Note: it is recommended that cables are marked on both ends.

For cord grip cable entry, take off the cord grip cover with bushing and run cable into enclosure, hand tighten cord grip cover to base to prevent damage of cord grip.



Figure 7. Front View



Figure 8. Bottom View

1. Strip outer jacket of cable back 1¼ in. and remove all of the shielding.
2. Separate the internal wires from the shield and twist the shield.
3. Strip red and black insulation back ¼ in.

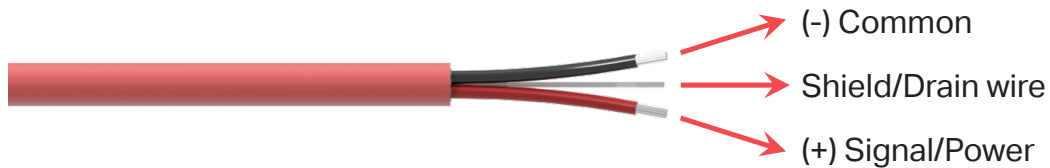
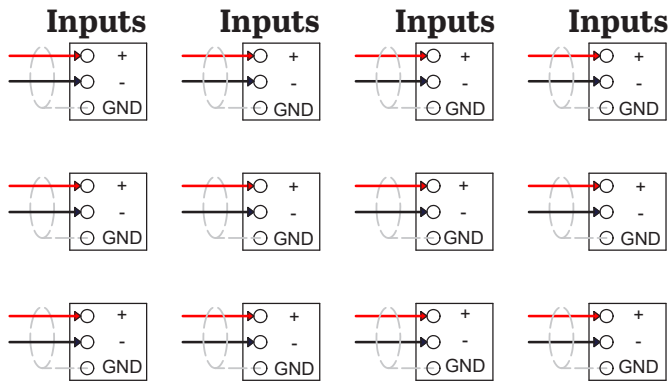

Figure 9. Stripped Wire

4. Locate the appropriate plug, identified by channel number, remove the plug and install the wires using a small flathead screwdriver. Push plug back into location. Orientation is as follows:
 - a. Red insulated conductor wire is connected to (+).
 - b. Black insulated conductor wire is connected to (-).
 - c. Shield drain wire is connected to ground (GND).
 - d. Depress selected position button to open terminal for respective wire (may require a mini flat head screwdriver).



Sensor Inputs
 Red = Positive Vibration
 Black = Common
 Grey = Shield (Ground)

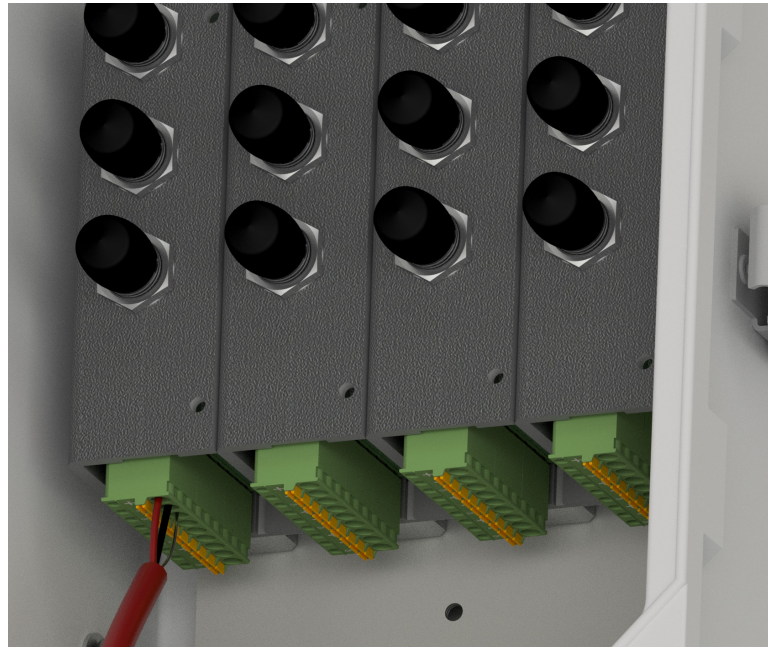

Figure 10. Connecting Cables to Termination box

5. Insert plug into the appropriate PC board connector and double check to ensure that the cable is going to the correct channel.
6. Mark the Measurement Location Card located on the inside front cover with a description of each measurement location.

POST INSTALLATION TESTING

The TM1018 Accelerometer Verification Meter can be used to verify cable conductivity, sensor location and proper wiring connections. The Verification Meter will indicate if the sensor, cable and/or junction box is in working condition. It will also confirm bias voltage of the accelerometer, which will inform you of the operation of the internal accelerometer amplifier.

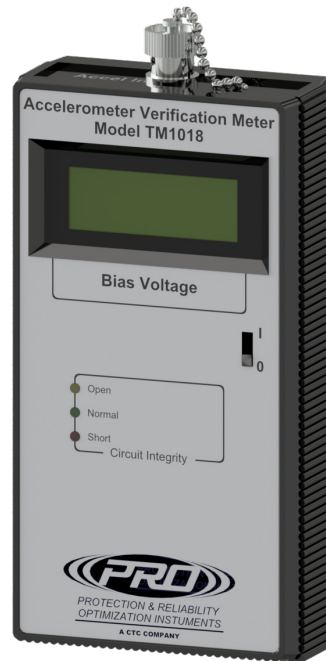

Figure 11. TM1018 Accelerometer Verification Meter

Testing Method:

1. Utilizing two personnel, Person A will be located at the termination box, while Person B will be located at the measurement location.
2. Once positioned, Person A will connect the TM1018 to the data collector output to the modular MAXX box and turn the Channel Selector to the channel that corresponds to the referenced measurement. Person A should observe a "NORMAL" LED reading.
3. Person B disconnects the cable from the accelerometer, and the TM1018 should respond with an "OPEN" LED. Reconnect the cable to the accelerometer, and the TM1018 should respond with a "NORMAL" LED.
4. Repeat for each measurement location to verify that accelerometer location is properly identified at the termination box.

The following LED Readout indicates the circuit integrity:

1. Green LED: Normal. Indicates proper connection and an output bias will be given, indicating the health of the sensor (4 – 16 V indicates a healthy accelerometer).
2. Yellow LED: Open Circuit. Indicates one of the following:
 - a. Cable connector is not connected to accelerometer.
 - b. Cable is open circuit (broken or not connected @ one end).
 - c. Accelerometer is not functioning correctly
3. Red LED: Short Circuit. Indicates one of the following:
 - a. Water or contamination in the connector.
 - b. Reverse Wiring ((+) and (-) leads are reversed).
 - c. Wires in termination box or cable connector (+) & (-) are touching.



WARRANTY & REFUND

Warranty

All CTC products are backed by our unconditional lifetime warranty. If any CTC product should ever fail, we will repair or replace it at no charge.

Refund

All stock products qualify for a full refund if returned in new condition within 90 days of shipment. Build to order products qualify for a 50% refund if returned in new condition within 90 days of shipment. Custom products are quoted and built specifically to the requirements of the customer, which may include completely custom product designs or private labeled versions of standard products for OEM customers. Custom products ordered are non-cancellable, non-returnable and non-refundable.

