

PRO SERIES

Instruction Manual



- Accepts Current, Voltage, TC, & RTD Inputs
- 4-Digit Display, 0.56" (14 mm)
- Linear or Square Root with Low-Flow Cutoff
- Maximum/Minimum Display
- Type 4X, NEMA 4X, IP65 Front
- Universal Power Supply 85-265 VAC
- 12-36 VDC/12-24 VAC Power Option
- Two Relays or 4-20 mA Output Option
- 24 VDC Transmitter Power Supply Options
- Serial Communication Adapters
RS-232 & RS-485 Options
- Free Modbus[®] RTU Protocol
- Copy Meter Settings to Other Meters
- MeterView[®] Software - Configuration & Data Acquisition

CONNECTION TECHNOLOGY CENTER INC
7939 Rae Blvd • Victor NY 14564 USA
Tel (800)999-5290 • (585)924-5900
Fax (585)924-4680



www.ctconline.com

Disclaimer

The information contained in this document is subject to change without notice. CTC makes no representations or warranties with respect to the contents hereof, and specifically disclaims any implied warranties of merchantability or fitness for a particular purpose.

Registered Trademarks

Modbus® is a registered trademark of Schneider Automation Inc. All other trademarks mentioned in this document are the property of their respective owners.

© 2007-2012 Connection Technology Center, Inc.. All rights reserved.

INTRODUCTION

The PRO is a multipurpose, easy to use digital meter. It accepts current, voltage, thermocouple, and RTD signals. The four front panel buttons make the setup and programming an easy task.

The isolated 24 VDC transmitter power (optional) can be used to power the input transmitter, the 4-20 mA output, or other devices.

The two relays (optional) can be used for alarm indication or process control applications, such as pump alternation control.

The 4-20 mA isolated output and the Modbus RTU serial communication options make the PRO an excellent addition to any system.

ORDERING INFORMATION

Reorder #	Power	Options Installed	Manufacturer #
PD765-6R0-00-PR	85-265 VAC	No options	PD765-6R0-00-PR
PD765-6R0-10-PR	85-265 VAC	24 V transmitter supply	PD765-6R0-10-PR
PD765-6R2-00-PR	85-265 VAC	2 relays	PD765-6R2-00-PR
PD765-6R2-10-PR	85-265 VAC	2 relays & 24 V transmitter supply	PD765-6R2-10-PR
PD765-6R3-00-PR	85-265 VAC	4-20 mA output	PD765-6R3-00-PR
PD765-6R3-10-PR	85-265 VAC	4-20 mA output & 24 V supply	PD765-6R3-10-PR
PD765-6R3-20-PR	85-265 VAC	4-20 mA output & dual 24 V supplies	PD765-6R3-20-PR
PD765-7R0-00-PR	12-36 VDC	No options	PD765-7R0-00-PR
PD765-7R2-00-PR	12-36 VDC	2 relays	PD765-7R2-00-PR
PD765-7R3-00-PR	12-36 VDC	4-20 mA output	PD765-7R3-00-PR

Manufactured by Precision Digital Corporation • 89 October Hill Road • Holliston, MA 01746 USA

Accessories

Model	Description
PDA7232-PR	RS-232 serial adapter with PDA7420-PR included
PDA7420-PR	PRO meter copy cable, 7' (2.1 m)
PDA7422-PR	RS-485 serial adapter with PDA7420-PR included
PDA7485-I-PR	RS-232 to RS-485 isolated converter
PDA7485-N-PR	RS-232 to RS-485 non-isolated converter
PDA8485-I-PR	USB to RS-422/485 isolated converter
PDA8485-N-PR	USB to RS-422/485 non-isolated converter

Table of Contents

INTRODUCTION	2
ORDERING INFORMATION	3
SPECIFICATIONS	7
General	7
Process Input	8
Temperature Inputs	9
Relays Option	10
Isolated 4-20 mA Transmitter Output	11
Serial Communications	11
COMPLIANCE INFORMATION	12
Safety	12
Electromagnetic Compatibility	12
SAFETY INFORMATION	13
INSTALLATION	14
Unpacking	14
Panel Mounting	14
Connections	15
Connector Labeling	15
Power Connections	15
Signal Connections	16
Serial Communication	19
Relays and 24 V Output Connections	19
Switching Inductive Loads	20
4-20 mA Output & Input Signal Connections	21
SETUP AND PROGRAMMING	22
Front Panel Buttons and Status LED Indicators	23
Display Functions and Messages	24
Main Menu	27
Setting Numeric Values	28
Setting Up the Meter (SETUP)	29
Setting the Input Signal (INPUT)	30
Setting the Decimal Point (DC.PT)	31
Setting the Temperature Scale (F/°C)	31
Setting the Relay Operation (RELAY)	32

Relay and Alarm Operation	35
Pump Alternation Control Operation	40
Scaling the 4-20 mA Analog Output (Rout)	41
Program the Sensor Break Output Value (SEbr)	42
Analog Output when Display is Out of Range	42
Programming the Meter (Prog)	43
Scaling the Meter (ScAL)	44
Calibrating the Meter (CAL)	46
Recalibrating Temperature Inputs (CAL)	46
Recalibrating Process Inputs (iCAL)	47
Setting Up the Password (PASS)	48
Locking the Meter	48
Unlocking the Meter	48
Advanced Features Menu	50
Advanced Features Menu & Display Messages	51
Offset Adjustment (Adj)	53
Noise Filter (FLtr)	53
Noise Filter Bypass (bYP5)	54
Serial Communications (SERL)	54
Protocol Selection Menu (Prot)	54
Select Menu (SELC)	55
Linear or Square Root Function (LInr or Sqrt)	55
Low-Flow Cutoff (cutf)	56
Display Intensity (intY)	56
Meter Copy Function (COPY)	57
Internal Calibration (iCAL)	59
OPERATION	62
Front Panel Buttons Operation	62
Maximum/Minimum Readings	63
MOUNTING DIMENSIONS	64
TROUBLESHOOTING	65
Diagnosics Menu (dAG)	65
Determining Software Version	65
Reset Meter to Factory Defaults	66
Factory Defaults & User Settings	67
Troubleshooting Tips	69
QUICK USER INTERFACE REFERENCE GUIDE	70

Table of Figures

Figure 1. Panel Cutout and Mounting	14
Figure 2. Connector Labeling for Two Relays & 24 V Supply.....	15
Figure 3. Power Connections	15
Figure 4. Transmitter Powered by Ext. Supply or Self-Powered	16
Figure 5. Transmitters Powered by Internal Supply (Optional)	16
Figure 6. Voltage Input Connections	17
Figure 7. Thermocouple Input Connections	17
Figure 8. Three-Wire RTD Input Connections	18
Figure 9. Two-Wire RTD Input Connections.....	18
Figure 10. Four-Wire RTD Input Connections.....	19
Figure 11. Relay & 24 V Output Connections.....	19
Figure 12. AC and DC Loads Protection.....	20
Figure 13. Low Voltage DC Loads Protection	20
Figure 14. 4-20 mA Output & Input Signal Powered by Meter	21
Figure 15. 4-20 mA Output Powered Externally.....	21
Figure 16. Meter Copy Connection	57
Figure 17. Meter Dimensions – Side View	64
Figure 18. Case Dimensions - Top View	64

SPECIFICATIONS

Except where noted all specifications apply to operation at +25°C.

General

DISPLAY	0.56" (14 mm) Four digits (-1999 to 9999), automatic lead zero blanking.
DISPLAY INTENSITY	Eight intensity levels
DISPLAY UPDATE RATE	Process/RTD: 3.7-5/second Thermocouple: 1.8-2.5/second
OVERRANGE	Display flashes 9999
UNDERRANGE	Display flashes - 1999
PROGRAMMING METHODS	Four front panel buttons, PC and MeterView® software, or cloning using Copy function
NOISE FILTER	Programmable from 2 to 199 (0 will disable filter)
RECALIBRATION	All ranges are calibrated at the factory. Recalibration is recommended at least every 12 months.
MAX/MIN DISPLAY	Max/min readings reached by the process are stored until reset by the user or until power to the meter is turned off.
PASSWORD	Programmable password restricts modification of programmed settings.
NON-VOLATILE MEMORY	All programmed settings are stored in non-volatile memory for a minimum of ten years if power is lost.
POWER OPTIONS	AC: 85-265 VAC, 50/60 Hz, DC: 90-265 VDC Models with transmitter option: 20 VA / 20 Watts Models without transmitter option: 8 VA / 8 Watts Optional: 12-36 VDC, 12-24 VAC, 6 Watts / 6 VA
FUSE	Required fuse: UL Recognized, 5 A max, slow blow Up to 6 meters may share one 5 A fuse
ISOLATED TRANSMITTER POWER SUPPLY	One or two transmitter power supplies (Optional) P or P1: 24 VDC ± 10% @ 200 mA max. (-1 option) P1 & P2: 24 VDC ± 10% @ 200 mA & 40 mA max. (-2 option)
NORMAL MODE REJECTION	64 dB at 50/60 Hz
ISOLATION	4 kV input/output-to-power line 500 V input-to-output or output-to-P1/P2 supplies
OVERVOLTAGE CATEGORY	Installation Overvoltage Category II: Local level with smaller transient overvoltages than Installation Overvoltage Category III.

ENVIRONMENTAL	Operating temperature range: 0 to 65°C Storage temperature range: -40 to 85°C Relative humidity: 0 to 90% non-condensing
CONNECTIONS	Removable screw terminal blocks accept 12 to 22 AWG wire, RJ11 for serial communication adapters
ENCLOSURE	1/8 DIN, high impact plastic, UL 94V-0, color: gray
MOUNTING	1/8 DIN panel cutout required. Two panel mounting bracket assemblies provided
TIGHTENING TORQUE	Screw terminal connectors: 4.5 lb-in (0.5 Nm)
OVERALL DIMENSIONS	2.45" x 4.68" x 4.19" (62 mm x 119 mm x 106 mm) (H x W x D)
WEIGHT	9.5 oz (269 g) (including options)
WARRANTY	3 years parts & labor
EXTENDED WARRANTY	1 or 2 years, refer to the Price List for details.

Process Input

INPUTS	Field selectable: ± 20 mADC (0-20, 4-20 mA) and ± 10 VDC (0-5, 1-5, 0-10 V)						
ACCURACY	$\pm 0.05\%$ of span ± 1 count, square root: 10-100% FS						
FUNCTION	Linear or square root						
LOW-FLOW CUTOFF	0-9999 (0 disables cutoff function)						
TEMPERATURE DRIFT	50 PPM/°C from 0 to 65°C ambient						
DECIMAL POINT	Up to three decimal places for process inputs: <i>dddd, dddd, dddd, or dddd</i>						
CALIBRATION RANGE	An <i>Error</i> message will appear if input 1 and input 2 signals are too close together. <table border="1"> <thead> <tr> <th>Input Range</th> <th>Minimum Span Input 1 & Input 2</th> </tr> </thead> <tbody> <tr> <td>4-20 mA</td> <td>0.40 mA</td> </tr> <tr> <td>± 10 V</td> <td>0.20 V</td> </tr> </tbody> </table>	Input Range	Minimum Span Input 1 & Input 2	4-20 mA	0.40 mA	± 10 V	0.20 V
Input Range	Minimum Span Input 1 & Input 2						
4-20 mA	0.40 mA						
± 10 V	0.20 V						
INPUT IMPEDANCE	Voltage ranges: greater than 1 M Ω Current ranges: 50 - 100 Ω (depending on resettable fuse impedance)						
INPUT OVERLOAD	Current input protected by resettable fuse. Fuse resets automatically after fault is removed.						

Temperature Inputs

INPUTS Field selectable: type J, K, T, or E thermocouples;
100 Ω platinum RTD (0.00385 or 0.00392 curve)

RESOLUTION 1° for all thermocouples and RTD inputs
1° or 0.1° for Type T thermocouple

ACCURACY

Input Type	Range	Accuracy
Type J	-58° to 1382° F -50° to 750°C	$\pm 2^\circ\text{F}$ $\pm 1^\circ\text{C}$
Type K	-58° to 2300° F -50° to 1260°C	$\pm 2^\circ\text{F}$ $\pm 1^\circ\text{C}$
Type T	-292° to 700° F -180° to 371°C	$\pm 2^\circ\text{F}$ $\pm 1^\circ\text{C}$
Type T 0.1° Res	-199.9° to 700.0° F -180.0° to 371.0°C	$\pm 1.8^\circ\text{F}$ $\pm 1.0^\circ\text{C}$
Type E	-58° to 1578° F -50° to 870°C	$\pm 2^\circ\text{F}$ $\pm 1^\circ\text{C}$
100 Ω RTD	-328° to 1382°F -200° to 750°C	$\pm 1^\circ\text{F}$ $\pm 1^\circ\text{C}$

COLD JUNCTION REFERENCE Automatic, fixed, no user calibration needed

TEMPERATURE DRIFT $\pm 2^\circ\text{C}$ maximum
0 to 65°C ambient temperature

OFFSET ADJUSTMENT Programmable to $\pm 19.9^\circ$. This parameter allows the user to apply an offset value to the temperature being displayed.

INPUT IMPEDANCE Greater than 100 k Ω

SENSOR BREAK DETECTION Open TC or RTD sensor indicated by display flashing **oPEN**. All relays and alarm status LEDs go to alarm state. Analog output goes to the programmed sensor break value.

Relays Option

RATING	2 SPDT (Form C); rated 3 A @ 30 VDC or 3 A @ 250 VAC resistive load; 1/14 HP @ 125/250 VAC (50 watts) for inductive loads
ELECTRICAL NOISE SUPPRESSION	A suppressor (snubber) should be connected to each relay contact switching inductive loads to prevent disruption to the microprocessor's operation. Recommended suppressor value: 0.01 μ F/470 Ω , 250 VAC (PDX6901-PR).
DEADBAND	0-100% of full scale, user selectable
HIGH OR LOW ALARM	User may program any alarm for high or low trip point.
RELAY OPERATION	Automatic (non-latching) Latching Pump alternation control
RELAY RESET	User selectable via front panel buttons or PC Automatic reset only (non-latching) Automatic + manual reset at any time (non-latching) Manual reset only, at any time (latching) Manual reset only after alarm condition has cleared (latching) Automatic reset: Relays will automatically reset when the input passes the reset point. Manual reset: Front panel ACK button. Pressing ACK resets all manually resettable relays.
TIME DELAY	0 to 199 seconds, on and off delays Programmable and independent for each relay
FAIL-SAFE OPERATION	Programmable Independent for each relay
AUTO INITIALIZATION	When power is applied to the meter, relays will reflect the state of the input to the meter.

Fail-safe operation: relay coil is energized in non-alarm condition. In case of power failure, relay will go to alarm state.

Isolated 4-20 mA Transmitter Output

OUTPUT RANGE	1.00 to 23.00 mA typical		
CALIBRATION	Factory calibrated for 4-20 mA		
SCALING RANGE	0.00 to 23.99 mA for any display range, see output range above		
ACCURACY	$\pm 0.1\%$ FS ± 0.004 mA		
TEMPERATURE DRIFT	0.4 μ A/ $^{\circ}$ C from 0 to 65 $^{\circ}$ C ambient Note: Analog output drift is separate from input drift.		
ISOLATED TRANSMITTER POWER SUPPLY	One or two transmitter power supplies (Optional) P1: 24 VDC $\pm 10\%$ @ 200 mA max. (-1 option) P1 & P2: 24 VDC $\pm 10\%$ @ 200 mA & 40 mA max. (-2 option)		
EXTERNAL LOOP POWER SUPPLY	35 VDC maximum		
OUTPUT LOOP RESISTANCE	Power supply	Minimum	Maximum
	24 VDC	10 Ω	700 Ω
	35 VDC (external)	100 Ω	1200 Ω

Serial Communications

METER ADDRESS	PDC protocol: 0 - 99 Modbus protocol: 1 - 247
BAUD RATE	300 – 19,200 bps
TRANSMIT TIME DELAY	Programmable between 0 and 199 ms or transmitter always on for RS422 communication
DATA	8 bit (1 start bit, 1 stop bit)
PARITY	None (1 or 2 stop bits), even, or odd (Modbus only; PDC protocol does not use parity)
BYTE-TO-BYTE TIMEOUT	0.01 – 2.54 sec (Modbus only)
TURN AROUND DELAY	Less than 2 ms (fixed)

Refer to PDC and Modbus Serial Communication Protocol manuals for details. These can be downloaded from: www.ctconline.com.

COMPLIANCE INFORMATION

Safety

UL LISTED	USA and Canada UL 508 Industrial Control Equipment
UL FILE NUMBER	E160849
FRONT PANEL	UL Type 4X, NEMA 4X, IP65; panel gasket provided
LOW VOLTAGE DIRECTIVE	EN 61010-1:2001 Safety requirements for measurement, control, and laboratory use

Electromagnetic Compatibility

EMISSIONS	EN 55011:2007 Group 1 Class A ISM emissions requirements
Radiated Emissions	Class A
AC Mains Conducted Emissions	Class A
IMMUNITY	EN 61326-1:2006 Measurement, control, and laboratory equipment EN 61000-6-2:2005 EMC heavy industrial generic immunity standard
RFI - Amplitude Modulated	80 -1000 MHz 10 V/m 80% AM (1 kHz) 1.4 - 2.0 GHz 3 V/m 80% AM (1 kHz) 2.0 - 2.7 GHz 1 V/m 80% AM (1 kHz)
Electrical Fast Transients	±2kV AC mains, ±1kV other
Electrostatic Discharge	±4kV contact, ±8kV air
RFI - Conducted	10V, 0.15-80 MHz, 1kHz 80% AM
AC Surge	±2kV Common, ±1kV Differential
Surge	1KV (CM)
Power-Frequency Magnetic Field	3 A/m 70%V for 0.5 period
Voltage Dips	40%V for 5 & 50 periods 70%V for 25 periods
Voltage Interruptions	<5%V for 250 periods

Note:

Testing was conducted on PRO Meters installed through the covers of grounded metal enclosures with cable shields grounded at the point of entry representing installations designed to optimize EMC performance.

Declaration of Conformity available at www.ctconline.com

SAFETY INFORMATION

CAUTION: Read complete instructions prior to installation and operation of the meter.



WARNING: Risk of electric shock.

**WARNING**

Hazardous voltages exist within enclosure. Installation and service should be performed only by trained service personnel.

INSTALLATION

There is no need to remove the meter from its case to complete the installation, wiring, and setup of the meter.

Unpacking

Remove the meter from box. Inspect the packaging and contents for damage. Report damages, if any, to the carrier.

If any part is missing or the meter malfunctions, please contact your supplier or the factory for assistance.

Panel Mounting

- Prepare a standard 1/8 DIN panel cutout – 3.622" x 1.772" (92 mm x 45 mm). Refer to *Mounting Dimensions*, page 64 for more details.
- Clearance: allow at least 4" (102 mm) behind the panel for wiring.
- Panel thickness: 0.04" - 0.25" (1.0 mm - 6.4 mm).
Recommended minimum panel thickness to maintain Type 4X rating: 0.06" (1.5 mm) steel panel, 0.16" (4.1 mm) plastic panel.
- Remove the two mounting brackets provided with the meter (back-off the two screws so that there is ¼" (6.4 mm) or less through the bracket. Slide the bracket toward the front of the case and remove).
- Insert meter into the panel cutout.
- Install mounting brackets and tighten the screws against the panel. To achieve a proper seal, tighten the mounting bracket screws evenly until meter is snug to the panel along its short side. **DO NOT OVER TIGHTEN**, as the rear of the panel may be damaged.

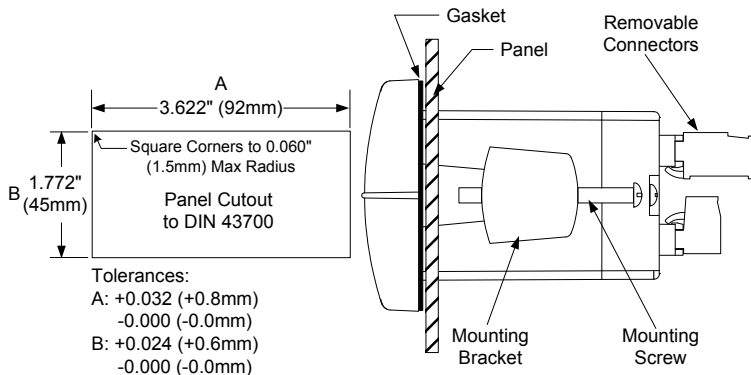

Figure 1. Panel Cutout and Mounting

Connections

All connections are made to removable screw terminal connectors located at the rear of the meter.



Use copper wire with 60°C or 60/75°C insulation for all line voltage connections. Observe all safety regulations. Electrical wiring should be performed in accordance with all applicable national, state, and local codes to prevent damage to the meter and ensure personnel safety.

Connector Labeling

The connectors label, affixed to the meter, shows the location of all connectors available with requested configuration. It also identifies the location of the RTD/TC selector switch.

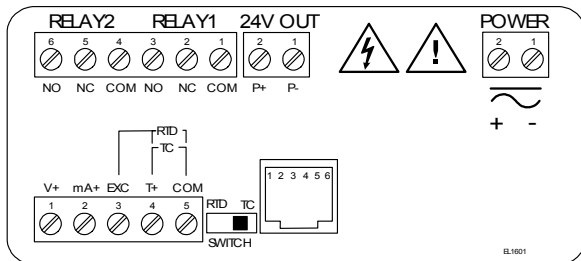

Figure 2. Connector Labeling for Two Relays & 24 V Supply

Power Connections

Power connections are made to a two-terminal connector labeled POWER on Figure 2. The meter will operate regardless of DC polarity connection. The + and - symbols are only a suggested wiring convention.

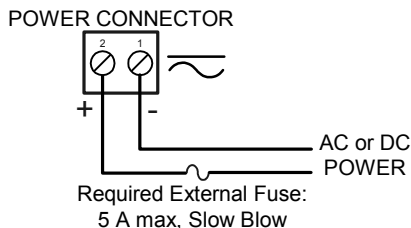

Figure 3. Power Connections

Signal Connections

Signal connections are made to a five-terminal connector labeled SIGNAL on Figure 2. The COM (common) terminal is the return for all types of input signals.

Current and Voltage Connections

The following figures show examples for current and voltage connections. There are no switches or jumpers to set up for current and voltage inputs. Setup and programming is performed through the front panel buttons.

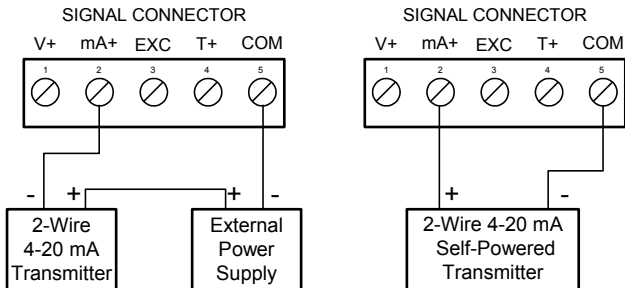

Figure 4. Transmitter Powered by Ext. Supply or Self-Powered

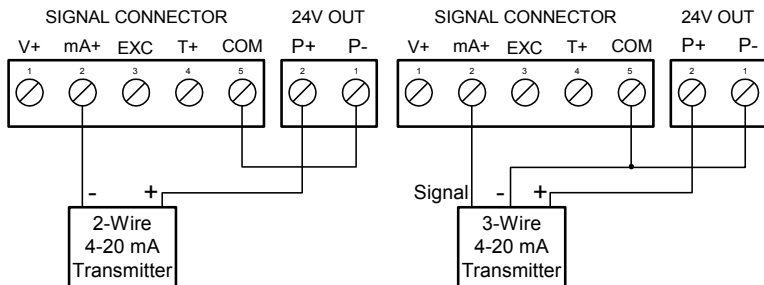

Figure 5. Transmitters Powered by Internal Supply (Optional)

The current input is protected against current overload by a resettable fuse. The display may or may not show a fault condition depending on the nature of the overload.

The fuse limits the current to a safe level when it detects a fault condition, and automatically resets itself when the fault condition is removed.

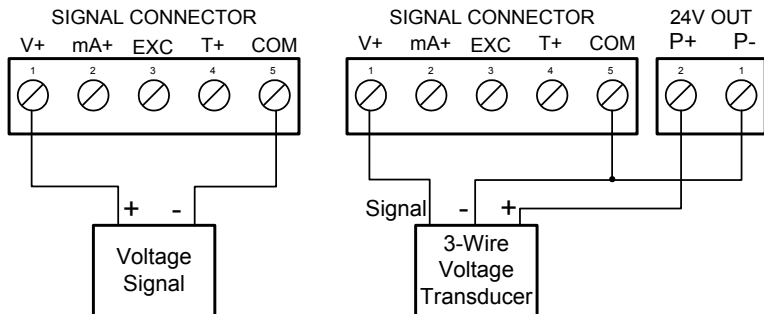

Figure 6. Voltage Input Connections

The meter is capable of accepting any voltage from -10 VDC to +10 VDC.

Thermocouple and RTD Connections

The following figures show examples for thermocouple and RTD connections.

The RTD/TC selector switch must be set to the proper position for the meter to accept the selected temperature input.

The input type is selected using the *Setup* menu.

Selected thermocouple input must correspond to thermocouple sensor and wire type used.

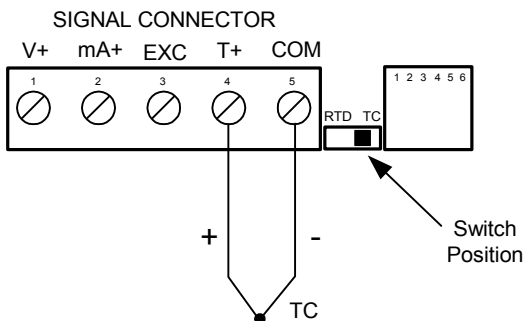

Figure 7. Thermocouple Input Connections

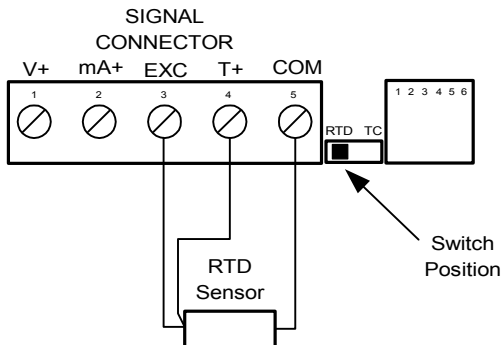

Figure 8. Three-Wire RTD Input Connections

The meter accepts two, three, or four-wire RTDs. The three-wire RTD connection has built-in lead wire compensation.

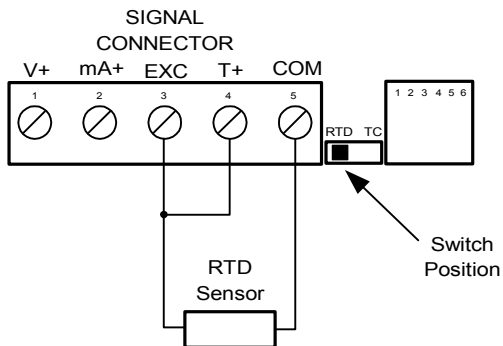

Figure 9. Two-Wire RTD Input Connections

Lead wire compensation for two-wire RTDs can be applied using the *Adjust* menu. See Offset Adjustment (Adj), page 53.

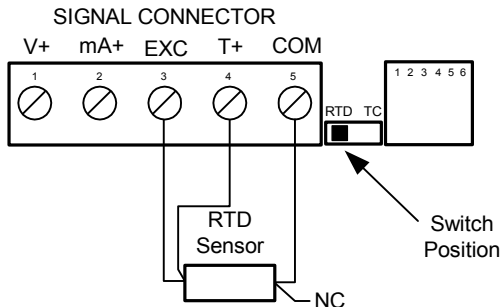

Figure 10. Four-Wire RTD Input Connections

The four-wire RTD connection is similar to the three-wire. One of the leads of a four-wire RTD is not connected, and may be clipped off. The three-wire connection provides sufficient lead wire compensation to provide accurate readings even with long leads.

Serial Communication

Serial communication connection is made to an RJ11 connector labeled SERIAL on Figure 2. Use PDA7232-PR for RS-232 interfacing.

Use PDA7422-PR for RS-485 interfacing.

Use PDA7420-PR for meter-to-meter interfacing for cloning purposes (*i.e.* copying programmed settings from one meter to other meters).

Relays and 24 V Output Connections

Relay connections are made to a six-terminal connector labeled RELAY1, RELAY2 on Figure 2. The COM (common) terminals of the relays should not be confused with the COM (common) terminal of the SIGNAL connector. The 24 VDC output is available at the connector labeled 24V OUT, next to the relays connector.

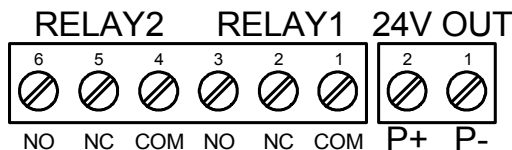

Figure 11. Relay & 24 V Output Connections

Switching Inductive Loads

The use of suppressors (snubbers) is strongly recommended when switching inductive loads to prevent disrupting the microprocessor's operation. The suppressors also prolong the life of the relay contacts. Suppression can be obtained with resistor-capacitor (RC) networks assembled by the user or purchased as complete assemblies. Refer to the following circuits for RC network assembly and installation:

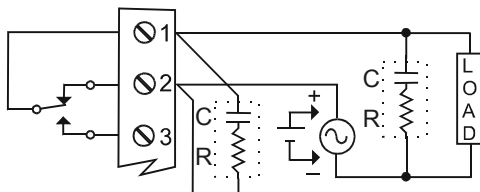

Figure 12. AC and DC Loads Protection

Choose R and C as follows:

R: 0.5 to 1 Ω for each volt across the contacts

C: 0.5 to 1 μF for each amp through closed contacts

Notes:

1. Inductive relay rating is 1/14 HP (50 W) at 115/230 VAC
2. Use capacitors rated for 250 VAC.
3. RC networks may affect load release time of solenoid loads. Check to confirm proper operation.
4. Install the RC network at the meter's relay screw terminals. An RC network may also be installed across the load. Experiment for best results.

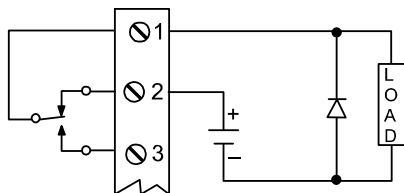

Use a diode with a reverse breakdown voltage two to three times the circuit voltage and forward current at least as large as the load current.

Figure 13. Low Voltage DC Loads Protection

RC Networks Available from CTC

RC networks are available from CTC and should be applied to each relay contact switching an inductive load. Part number: PDX6901-PR.

Note: Relays are de-rated to 1/14th HP (50 watts) with an inductive load.

4-20 mA Output & Input Signal Connections

Connections for the 4-20 mA transmitter output are made to the connector terminals labeled "mA OUT, I-, I+". The 4-20 mA output may be powered from an internal power supply (optional) or from an external power supply.

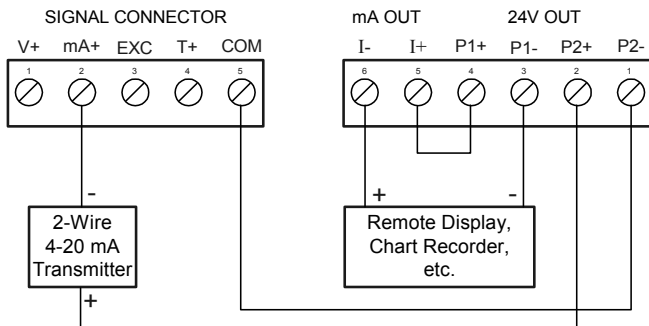

Figure 14. 4-20 mA Output & Input Signal Powered by Meter

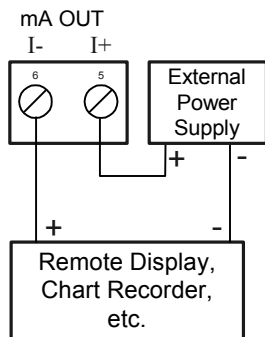
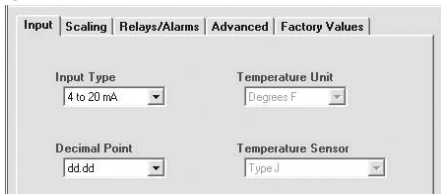

Figure 15. 4-20 mA Output Powered Externally

SETUP AND PROGRAMMING

Programming From a PC with MeterView®

MeterView® software allows all PRO setup parameters to be programmed from a PC (requires PDC protocol selection) and to save the configuration settings to a file for reporting or programming other meters. And since the serial adapter is an external device, one serial adapter can program an infinite number of meters!



The MeterView screen shot above shows how the input is selected. Notice there are tabs for Scaling, Relays/Alarms, Advanced, and Factory Values.

- There is **no need to recalibrate** the meter when first received from the factory.
- The meter is **factory calibrated** prior to shipment, for all input types, in milliamps, volts, and degrees respectively. The calibration equipment is certified to NIST standards.

Overview

There are no jumpers involved in the setup process of the meter. The RTD/TC selector switch, located between the SIGNAL and SERIAL connectors, must be set accordingly for the meter to accept RTD or thermocouple inputs, Figure 2.





Setup and programming is done through the front panel buttons.

After power and signal connections have been completed and verified, apply power to the meter.

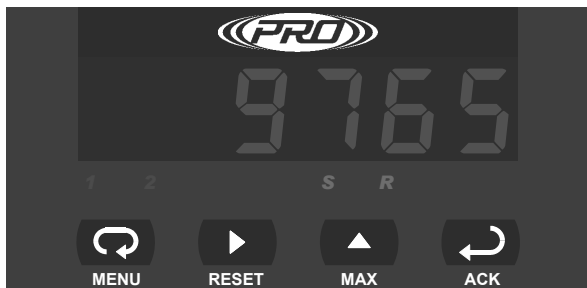
For
**Quick User Interface Reference
Guide** go to page 70

Front Panel Buttons and Status LED Indicators



Button Symbol	Description	LED	Status
	Menu	1	Alarm 1
	Right arrow/Reset	2	Alarm 2
	Up arrow/Max	S	Set point indicator
	Enter/Ack	R	Reset point indicator

- Press the **Menu** button to enter or exit the Programming Mode at any time.
- Press the **Right** arrow button to move to the next digit during digit programming.
- Press the **Up** arrow button to scroll through the menus, decimal point, or to increment the value of a digit.
- Press the **Enter/Ack** button to access a menu or to accept a setting.
- Press and hold the **Right** arrow and the **Menu** buttons, for three seconds, to access the Advanced features of the meter (Press and hold **Right** arrow first then **Menu**).

Display Functions and Messages

The meter displays various functions and messages during set-up/programming and operation. The following table shows the displayed functions and messages with their action/setting description.

Display	Parameter	Action/Setting
SE <u>tu</u>	<i>Setup</i>	Enter <i>Setup</i> menu
<u>in</u> P <u>t</u>	<i>Input</i>	Enter <i>Input</i> menu
4-2 <u>0</u>	4-20 mA	Set meter for 4-20 mA input
0-1 <u>0</u>	0-10 VDC	Set meter for ± 10 VDC input
<u>rt</u> d	<i>RTD</i>	Set meter for RTD input
R <u>385</u>	<i>Alpha 385</i>	Set $\alpha = 0.00385$ European curve 100 Ω RTD
R <u>392</u>	<i>Alpha 392</i>	Set $\alpha = 0.00392$ American curve 100 Ω RTD
<u>t</u> C	<i>TC</i>	Set meter for TC input
0 <u>J</u> 0 <u>J</u>		Type J
1 <u>H</u> 1 <u>K</u>		Type K
2 <u>t</u> 2 <u>T</u>		Type T
3 <u>t.0</u>	3 T.0	Type T, 0.1° resolution
4 <u>E</u> 4 <u>E</u>		Type E
F <u>C</u>	$^{\circ}$ F or $^{\circ}$ C	Set temperature scale
<u>o</u> F	$^{\circ}$ F	Set meter to Fahrenheit
<u>o</u> C	$^{\circ}$ C	Set meter to Celsius
<u>d</u> E <u>c</u> . <u>P</u>	<i>Decimal point</i>	Set decimal point for process inputs
<u>r</u> E <u>L</u> <u>y</u>	<i>Relay</i>	Enter the <i>Relay</i> menu
<u>r</u> L <u>y</u> 1	<i>Relay1</i>	Relay 1 setup
R <u>ct</u> 1	<i>Action1</i>	Set relay 1 action (automatic, latching, etc.)
R <u>u</u> t <u>o</u>	<i>Automatic</i>	Set relay for automatic reset
R- <u>o</u> <u>n</u>	<i>Auto-manual</i>	Set relay for automatic + manual reset any time
L <u>E</u> C <u>H</u>	<i>Latching</i>	Set relay for latching operation

Display	Parameter	Action/Setting
L-CL	Latching-cleared	Set relay for latching operation with manual reset only after alarm condition has cleared
RLtr	Alternate	Set relays for pump alternation control
oFF	Off	Disable relay and front panel status LEDs Disable relay's fail-safe operation
SEt 1	Set1	Program set point 1
rSEt 1	Reset1	Program reset point 1
rLY2	Relay2	Setup relay 2
Rct2	Action2	Set relay 2 action (automatic, latching, etc.)
SEt2	Set2	Program set point 2
rSEt2	Reset2	Program reset point 2
FLSF	Fail-safe	Enter <i>Fail-safe</i> menu
FLS 1	Fail-safe1	Set relay 1 fail-safe operation
on	On	Enable fail-safe operation
FLS2	Fail-safe2	Set relay 2 fail-safe operation
dLRY	Delay	Enter <i>Time Delay</i> menu
dLY 1	Delay1	Enter relay 1 time delay setup
On 1	On1	Set relay 1 On time delay
OFF 1	Off1	Set relay 1 Off time delay
dLY2	Delay2	Enter relay 2 time delay setup
On2	On2	Set relay 2 On time delay
OFF2	Off2	Set relay 2 Off time delay
Rout	Analog output	Enter the <i>Analog output</i> menu
SEbr	Sensor break	Program TC or RTD sensor break value for analog out
out 1	Output 1	Program output 1 value (e.g. 4 mA)
out2	Output 2	Program output 2 value (e.g. 20 mA)
Prog	Program	Enter the <i>Program</i> menu
ScAL	Scale	Enter the <i>Scale</i> menu
CAL	Calibrate	Enter the <i>Calibrate</i> menu

Display	Parameter	Action/Setting
<i>inP 1</i>	<i>Input 1</i>	Calibrate input 1 signal or program input 1 value
<i>d 1S 1</i>	<i>Display 1</i>	Program display 1 value
<i>inP 2</i>	<i>Input 2</i>	Calibrate input 2 signal or program input 2 value
<i>d 1S 2</i>	<i>Display 2</i>	Program display 2 value
<i>Err</i>	<i>Error</i>	Error, calibration not successful, check signal
<i>PR55</i>	<i>Password</i>	Enter the <i>Password</i> menu
<i>unLk</i>	<i>Unlocked</i>	Program password to lock meter
<i>LoCd</i>	<i>Locked</i>	Enter password to unlock meter
<i>9999</i> <i>- 1999</i> <i>oPEn</i>	<i>Flashing display</i>	Overrange condition Underrange condition Open TC or RTD sensor

Main Menu

The main menu consists of the most commonly used functions: *Setup*, *Program*, and *Password*.

- Press **Menu** button to enter Programming Mode then press **Up** arrow button to scroll main menu.

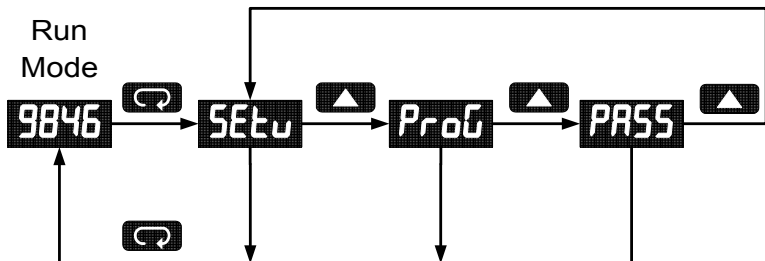

- Press **Menu**, at any time, to exit and return to Run Mode. Changes made to settings prior to pressing **Enter/Ack** are not saved.
- Changes to the settings are saved to memory only after pressing **Enter/Ack**.
- The display moves to the next menu every time a setting is accepted by pressing **Enter/Ack**.

Setting Numeric Values

The numeric values are set using the **Right** and **Up** arrow buttons. Press **Right** arrow to select next digit and **Up** arrow to increment digit value.

The digit being changed is displayed brighter than the rest.

Press the **Enter/Ack** button, at any time, to accept a setting or **Menu** button to exit without saving changes.

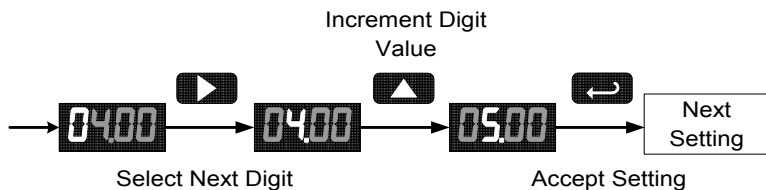

The decimal point is set using the **Up** arrow button in the *Setup-decimal point* menu.

Setting Up the Meter (SEtU)

The *Setup* menu is used to select:

1. Input signal the meter will accept
2. Decimal point position for process inputs
3. Units (°F or °C) for temperature inputs
4. Relay operation
5. 4-20 mA analog output set up

Press the **Enter/Ack** button to access any menu or press **Up** arrow button to scroll through choices. Press the **Menu** button to exit at any time.

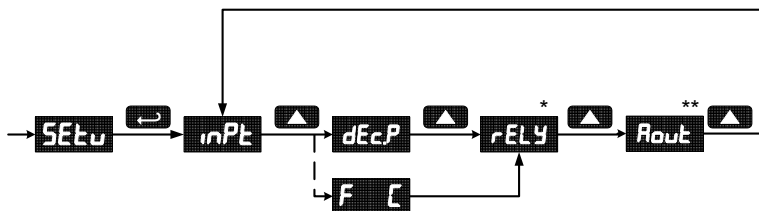

* Relay menu is always available even if relays option is not installed. Visual alarm indication is available through front panel LEDs and MeterView software.

** Analog Output menu is available if selected in the Advanced Features menu. 4-20 mA output option board is installed and set up at the factory.

Setting the Input Signal (mPt)

Enter the *Input* menu to set up the meter to display current (4-20), voltage (0-10), thermocouple (tC), or RTD (rtd) inputs.

The voltage input is capable of accepting any signal from -10 to +10 VDC. Select voltage input to accept 0-5, 1-5, 0-10, or ± 10 VDC signals. The current input is capable of accepting any signal from -20 to 20 mA. Select current input to accept 0-20 or 4-20 mA signals.

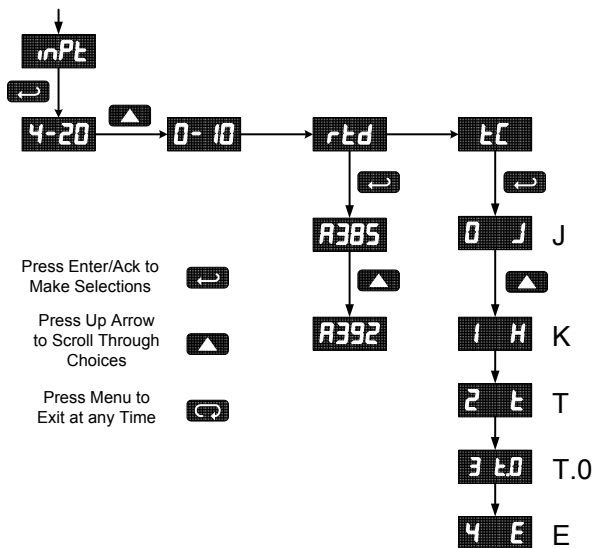

If RTD is selected, the display shows **R385** or **R392**. Select the coefficient to match the RTD sensor, either 0.00385 (European curve) or 0.00392 (American curve).

If TC is selected, scroll through the thermocouple types and select the type matching the TC sensor.

The input signal must be connected to the appropriate input terminals and the RTD/TC selector switch must be set accordingly, see Figure 7 on page 17.

For thermocouple inputs, allow at least 30 minutes warm-up time for meter to reach specified accuracy.

Setting the Decimal Point (*dE_cPt*)

Decimal point for temperature inputs is fixed.

Decimal point for process inputs may be set with up to three decimal places or with no decimal point at all.

Pressing the **Up** arrow moves the decimal point one place to the right until no decimal point is displayed, then it moves to the leftmost position.

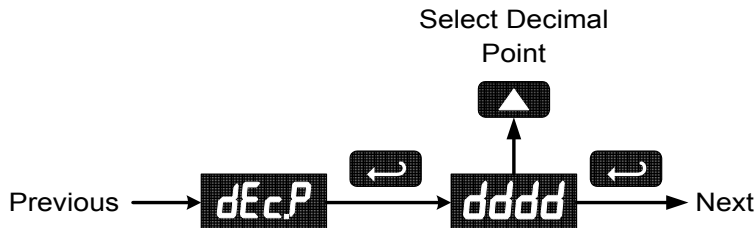

Setting the Temperature Scale (*F* $^{\circ}$ $^{\circ}$ $^{\circ}$ $^{\circ}$)

The meter can be set to display temperature in degrees Fahrenheit or Celsius.

Press **Up** arrow to change selection.

Press **Enter/Ack** to accept.

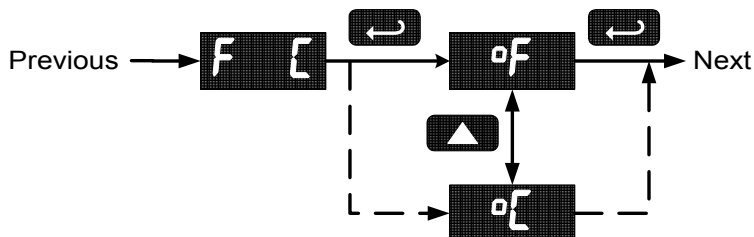

Setting the Relay Operation (rELY)

This menu allows you to set up the operation of the relays:

1. Relay action
 - a. Automatic reset only (non-latching)
 - b. Automatic + manual reset at any time (non-latching)
 - c. Latching (manual reset only)
 - d. Latching with Clear (manual reset only after alarm condition has cleared)
 - e. Pump alternation control (automatic reset only)
 - f. Off (relay and status LED disabled)
2. Set point
3. Reset point
4. Fail-safe operation
 - a. On (enabled)
 - b. Off (disabled)
5. Time delay
 - a. On delay (0-199 seconds)
 - b. Off delay (0-199 seconds)

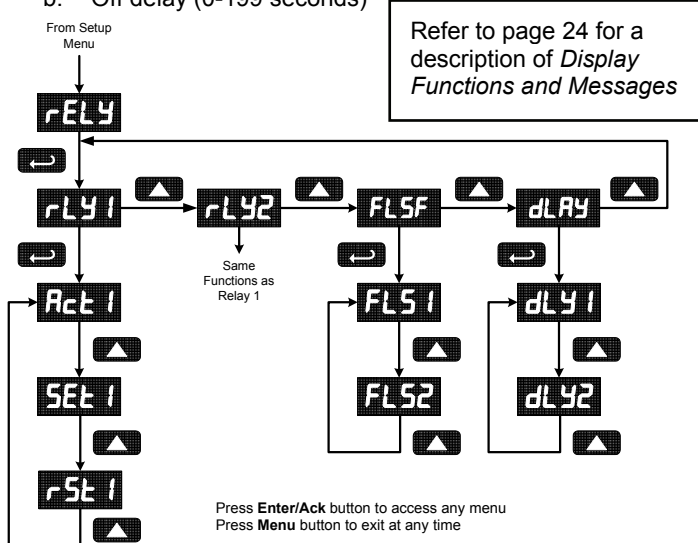

Setting the Relay Action

The relays' *Action* menu allows the user to set up the operation of the relays. The relays may be set up for any of the following modes of operation:

1. Automatic reset (non-latching)
2. Automatic + manual reset at any time (non-latching)
3. Latching (manual reset only, at any time)
4. Latching with Clear (manual reset only after alarm condition has cleared)
5. Pump alternation control (automatic reset only)
6. Off (relay and status LED disabled)

The following graphic shows relay 1 action setup; relay 2 is set up in a similar fashion.

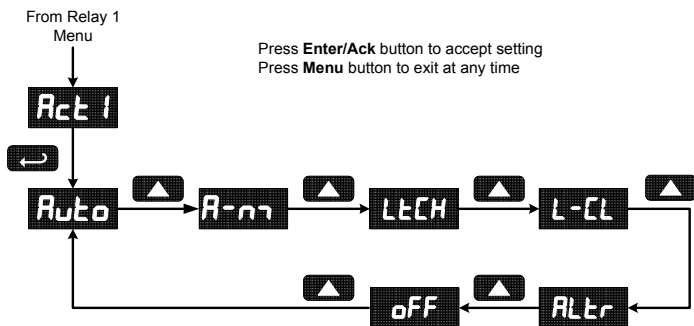

Programming Set and Reset Points

High alarm indication: program set point above reset point.

Low alarm indication: program set point below reset point.

The deadband is determined by the difference between set and reset points. Minimum deadband is one display count. If set and reset points are programmed the same, relay will reset one count below set point.

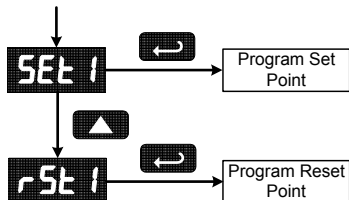

Quick Set Points

Press **Up** arrow and **Menu** at the same time to access set/reset points quickly.

Setting Fail-Safe Operation

The fail-safe operation is set independently for each relay. Select **on** to enable or select **off** to disable fail-safe operation.

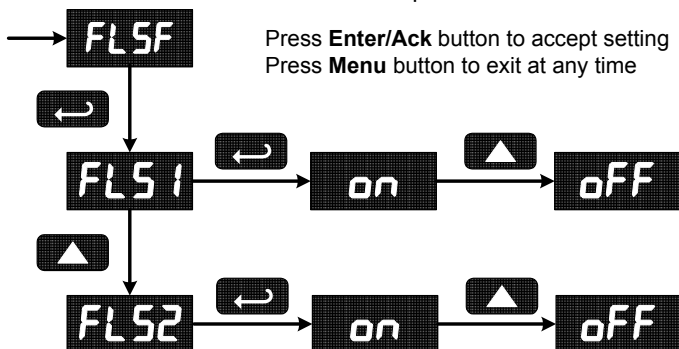

Programming Time Delay

The *On* and *Off* time delays may be programmed for each relay between 0 and 199 seconds. The relays will transfer only after the condition has been maintained for the corresponding time delay.

The *On* time delay is associated with the set point.

The *Off* time delay is associated with the reset point.

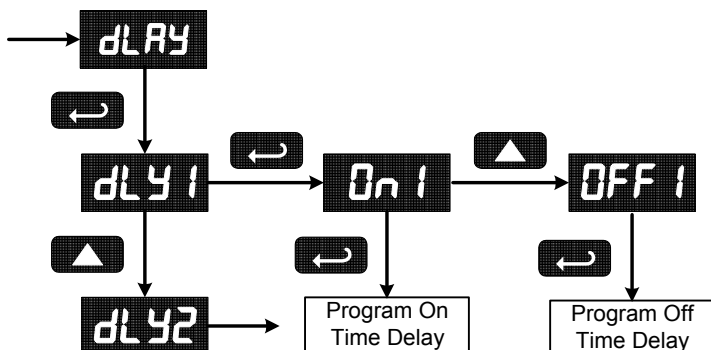

Relay and Alarm Operation

The following graphs illustrate the operation of the relays, status LEDs, and ACK button.

High Alarm Operation (Set > Reset)

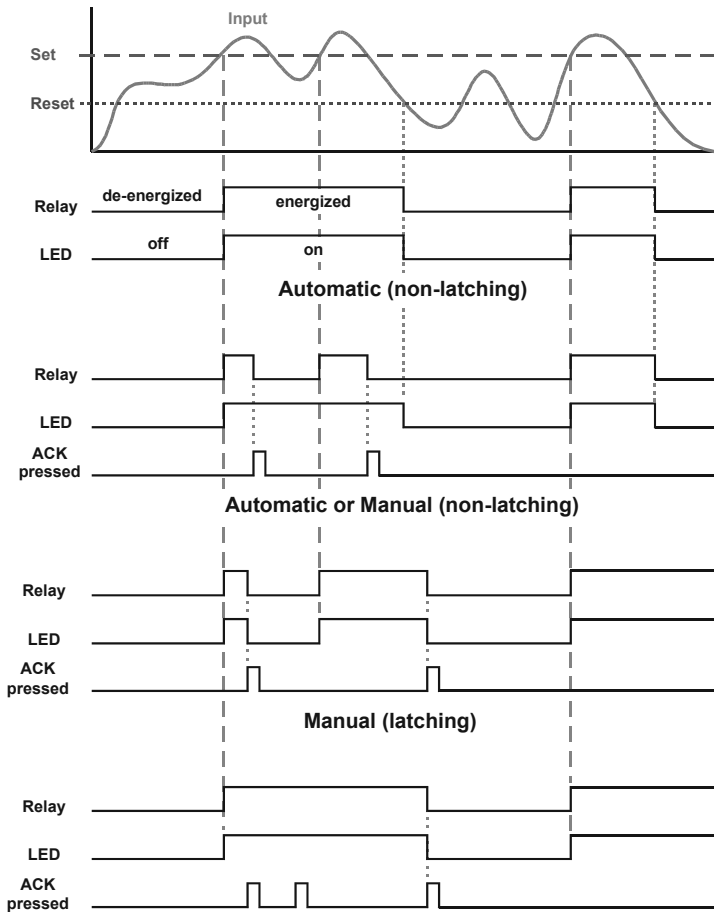

Manual only after passing below Reset (latching with clear)

For Manual reset mode, ACK can be pressed anytime to turn "off" relay. For relay to turn back "on", signal must go below set point, and then go above it.

Low Alarm Operation (Set < Reset)

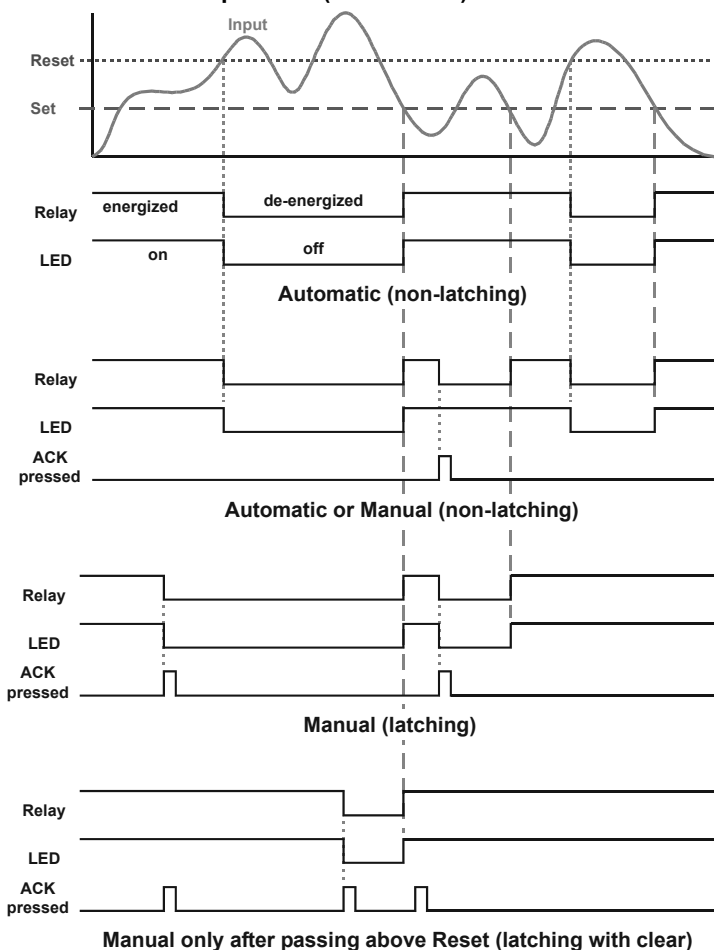

For Manual reset mode, ACK can be pressed anytime to turn "off" relay. For relay to turn back "on", signal must go above set point, and then go below it.

Time Delay Operation

The following graphs show the operation of the time delay function.

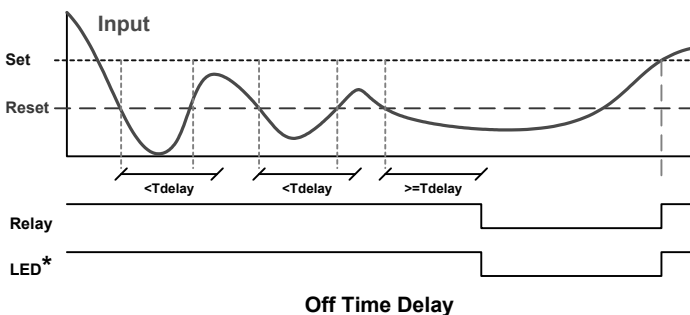
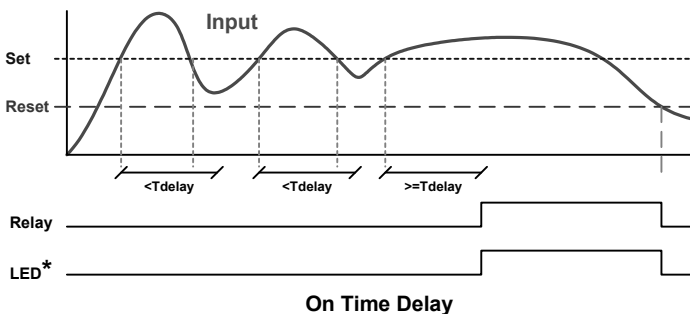

If the signal crosses the set point, the *On* time delay timer starts and the relay trips when the time delay has elapsed. If the signal drops below the set point (high alarm) before the time delay has elapsed, the *On* time delay timer resets and the relay does not change state. The same principle applies to the *Off* time delay.

* Note: The LED is not affected by Time Delay when “*Automatic or Manual*” reset mode is selected. Rather the LED follows the set and reset points.

High Alarm with Fail-Safe Operation (Set > Reset)

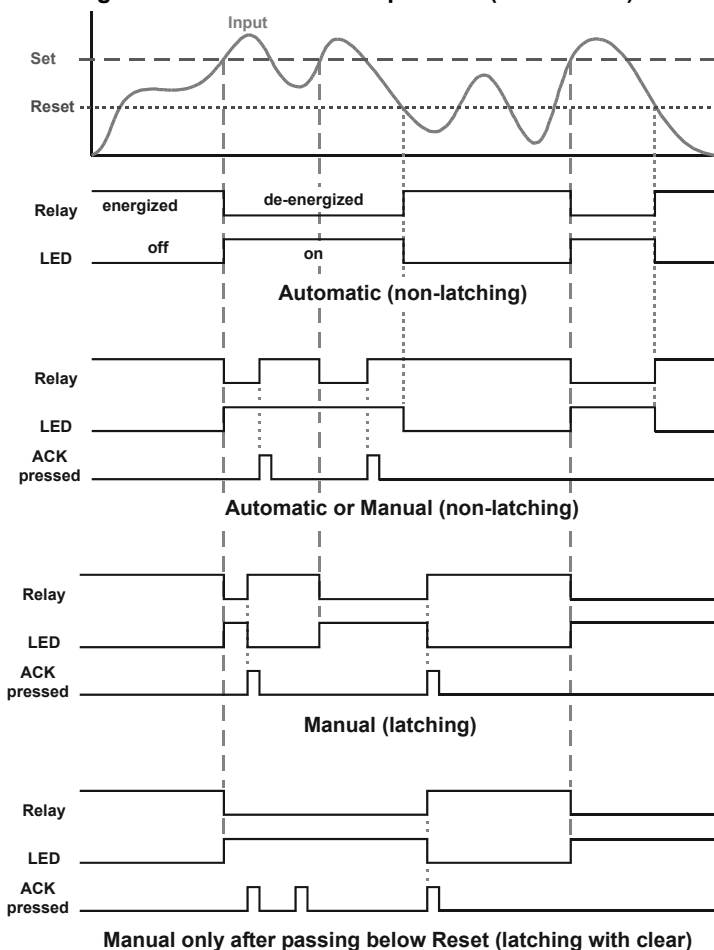

Fail-safe operation: relay coil is energized in non-alarm condition. In case of power failure, relay will go to alarm state.

Low Alarm with Fail-Safe Operation (Set < Reset)

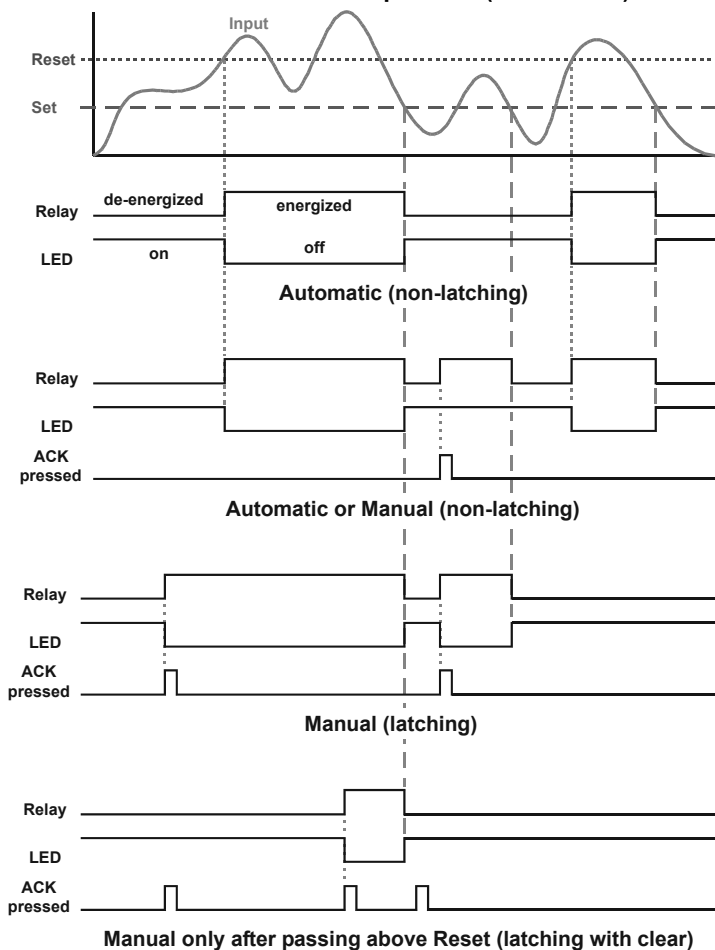

Fail-safe operation: relay coil is energized in non-alarm condition. In case of power failure, relay will go to alarm state.

Pump Alternation Control Operation

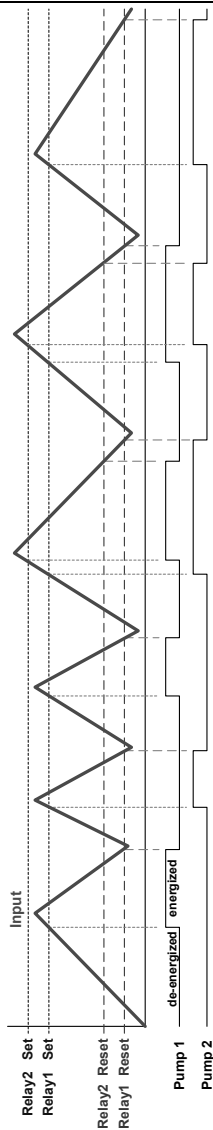
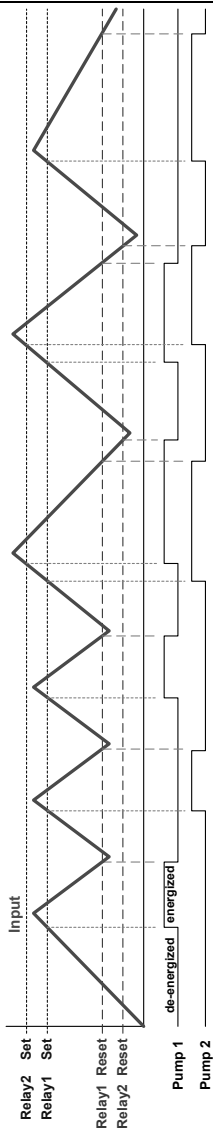
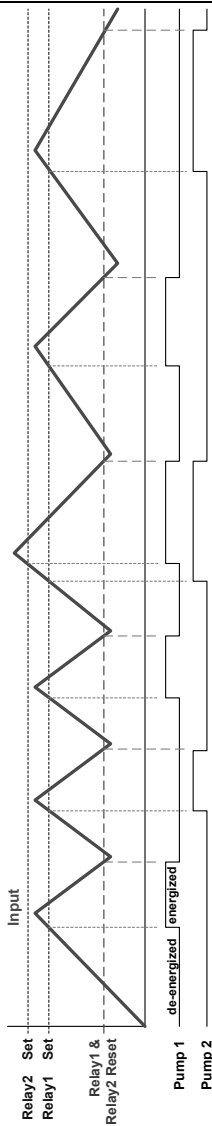

LEDs indicate the relay status

Scaling the 4-20 mA Analog Output (*Rout*)

The 4-20 mA analog output can be scaled to provide a 4-20 mA signal for any display range selected.

No equipment is needed to scale the analog output; simply program the display values to the corresponding mA output signal.

The *Analog Output* menu is used to program:

1. 4-20 mA output based on display values
2. Sensor break value in mA

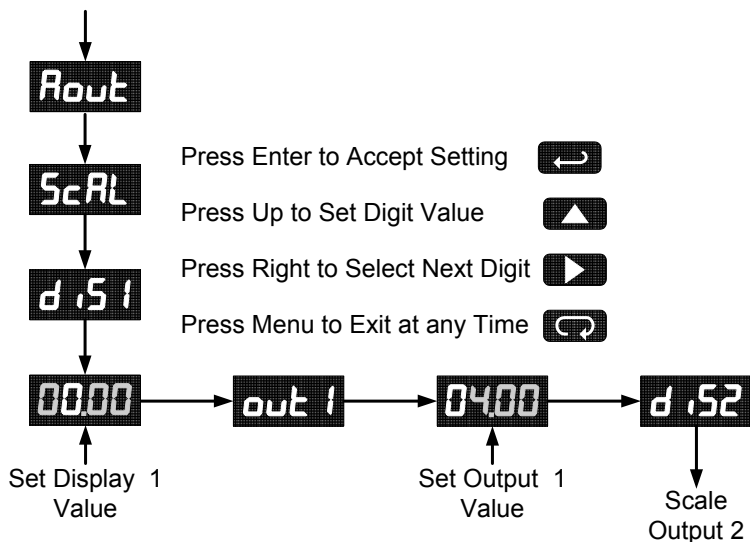

For instructions on how to program numeric values see *Setting Numeric Values*, page 28.

Program the Sensor Break Output Value (SEbr)

The sensor break value corresponds to the output signal generated when the meter detects a sensor break for thermocouple and RTD inputs.

For example if there is an open thermocouple, the meter displays the message “*oPEr*” and the analog output goes to the programmed sensor break value (e.g. 3.00 mA).

The sensor break value can be programmed from 0.00 to 23.99. The typical output signal range is 1.00 to 23.00 mA (e.g. If sensor break value is programmed to 0.00, the actual output will not be greater than 1.00 mA).

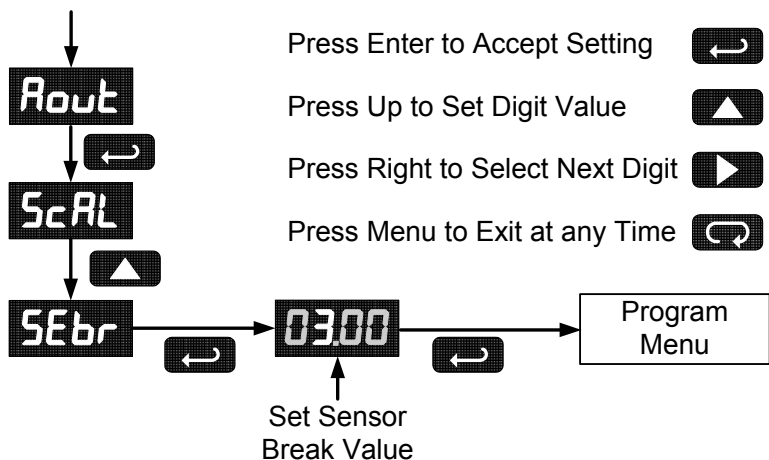

Analog Output when Display is Out of Range

The analog output reflects the display out of range conditions as follows:

Input Condition	Display	Analog Output
Underrange	Flashing - 1999	3.00 mA
Overrange	Flashing 9999	21.00 mA
Open TC or RTD	Flashing <i>oPEr</i>	Sensor break value

Programming the Meter (Prog)

It is **very important** to read the following information, before proceeding to program the meter:

- There is **no need to recalibrate** the meter when first received from the factory.
- The meter is **factory calibrated** prior to shipment, for all input types, in milliamps, volts, and degrees respectively. The calibration equipment is certified to NIST standards.
- Use the *Scale* menu to scale process inputs (e.g. 4-20 mA). A calibrated signal source is not needed to scale the meter.
- For thermocouple and RTDs, just connect the sensor to the proper terminals and turn the power on. **No calibration needed!** (when the meter is first received from the factory).

The *Program* menu contains the *Calibrate* and the *Scale* menus.

Process inputs may be calibrated or scaled to any display within the range of the meter.

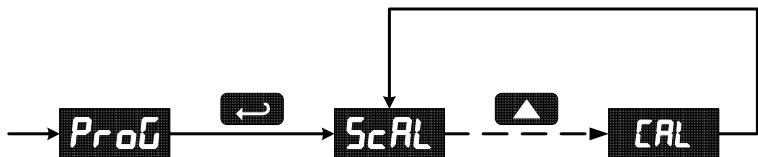

Additional parameters, not needed for most applications, are programmed with the *Advanced features* menu, see *Advanced Features Menu*, page 50.

Scaling the Meter (ScAL)

The process inputs (4-20 mA and ± 10 VDC) can be scaled to display the process in engineering units.

A signal source is not needed to scale the meter; simply program the inputs and corresponding display values.

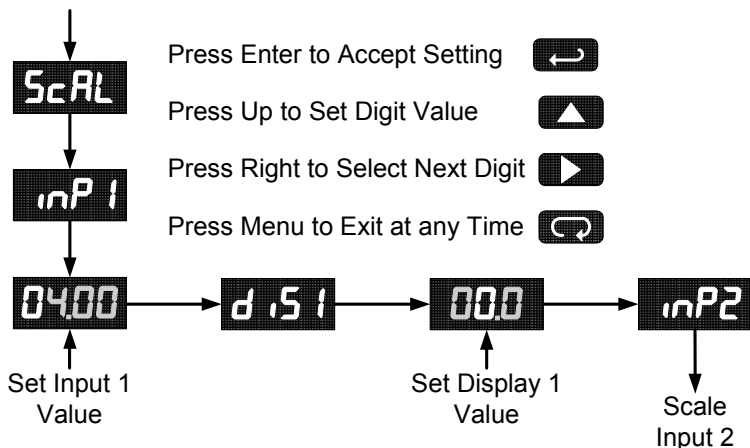

For instructions on how to program numeric values see *Setting Numeric Values*, page 28.

Note:

The *Scale* menu is not available for temperature inputs.

Error Message (*Err*)

An error message indicates that the calibration or scaling process was not successful.

After the error message is displayed, the meter reverts to input 1, allowing the appropriate input signals to be applied.

The error message might be caused by any of the following conditions:

1. Input signal is not connected to the proper terminals or it is connected backwards.
2. Wrong signal selection in *Setup* menu.
3. Minimum input span requirements not maintained.
4. Input 1 signal inadvertently applied to calibrate input 2.

Minimum Input Span

The minimum input span is the minimum difference between input 1 and input 2 signals required to complete the calibration or scaling of the meter.

Input range	Input 1 & input 2 span
4-20 mA	0.40 mA
±10 VDC	0.20 VDC
TC	100°F (56°C)
RTD	50°F (28°C)

Calibrating the Meter (CAL)

To scale the meter without a signal source refer to *Scaling the Meter (scal)*, page 44.

The meter can be calibrated to display the process in engineering units by applying the appropriate input signal and following the calibration procedure.

The use of a calibrated signal source is strongly recommended to calibrate the meter.

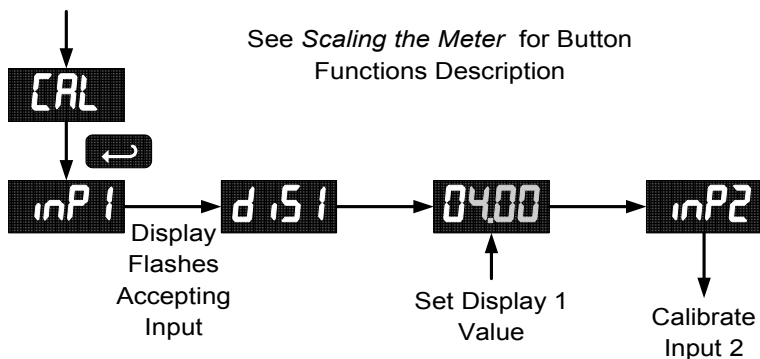

Recalibrating Temperature Inputs (CAL)

Remember, the meter is **calibrated** at the factory prior to shipment. Recalibration is recommended at least every twelve months.

The *Calibration (CAL)* menu is used to **recalibrate** the thermocouple and RTD inputs.

Allow at least 30 minutes warm-up time before performing recalibration procedure to ensure specified accuracy.

Recommended Calibration Points

To recalibrate the meter, it is recommended to use the Fahrenheit scale; this will give a greater degree of accuracy to the calibration. The scale can be changed to the Celsius scale after calibration is completed. The meter will display temperature accurately in any scale. The following table shows the recommended low and high calibration points for all types.

Type of input	Input 1 (Low)	Input 2 (High)	Check (Middle)
Type J T/C	32°F	1182°F	600°F
Type K T/C	32°F	1893°F	960°F
Type T T/C	32°F	693°F	360°F
Type T T/C	32.0°F	693.0°F	360.0°F
Type E T/C	32°F	1652°F	840°F
100 Ω RTD (0.00385)	32°F 100Ω	1148°F 320.12Ω	590°F 215.61Ω
100 Ω RTD (0.00392)	32°F 100Ω	1127°F 320.89Ω	580°F 215.87Ω

Recalibration Procedure for Temperature Inputs

1. Connect signal to the meter using the appropriate wire (e.g. type J thermocouple wire to recalibrate type J input), see page 17.
2. Set up the meter to accept the selected input (e.g. type J T/C), see page 30.
3. Set up the meter to display temperature in degrees Fahrenheit, see page 31.
4. Apply signal corresponding to input 1 (32°F) and program display 1 to 32, see page 46.
5. Apply signal corresponding to input 2 (1182°F for type J) and program display 2 accordingly, see page 46.
6. After the meter accepts input 2, the display flashes the message $\llcorner J$ that indicates the meter is sensing the cold junction reference. This completes the recalibration procedure for the selected input.

Recalibrating Process Inputs ($\llcorner RL$)

The *Internal Calibration* ($\llcorner RL$) menu, located in the Advanced features menu, is used to recalibrate the current and voltage inputs. Recalibration is recommended at least every twelve months.

Refer to Internal Calibration (ICal), page 59 for instructions.

Setting Up the Password (PASS)

The *Password* menu is used to program a four-digit password to prevent unauthorized changes to the programmed parameter settings.

Locking the Meter

Enter the *Password* menu and program a four-digit password.

For instructions on how to program numeric values see *Setting Numeric Values*, page 28.

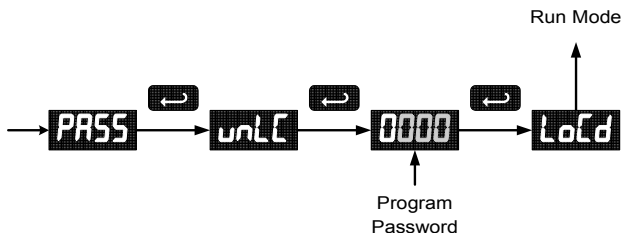

Record the password for future reference. If appropriate, it may be recorded in the space provided.

Model:	
Serial Number:	
Password:	__ __ __ __

Unlocking the Meter

If the meter is password protected, the correct password must be entered in order to make changes to the parameter settings.

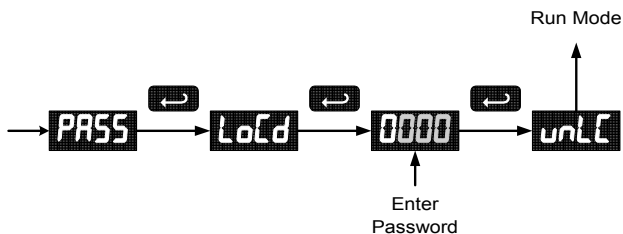

Entering the correct four-digit number sets the password to 0000, disabling the protection.

Changes to the programmed parameter settings are allowed only with the password set to 0000.

If the password entered is incorrect, the meter displays *LoCd* (Locked) for about two seconds, then it returns to Run Mode. To try again, press **Enter/Ack** while the *Locked* message is displayed.

Forgot the Password?

The password may be disabled by the following procedure:

1. Note display reading prior to pressing the Menu button. Ignore decimal point and sign.
2. Access the *Password* menu, add 2 to the noted reading and enter that number as the password (e.g. display reading = -1.23, password = 0125).

Advanced Features Menu

To simplify the setup process, functions not needed for most applications are located in the *Advanced* features menu.

Press and hold the **Right** arrow and the **Menu** buttons, for three seconds, to access the Advanced features of the meter (Press and hold **Right** arrow first then **Menu**).

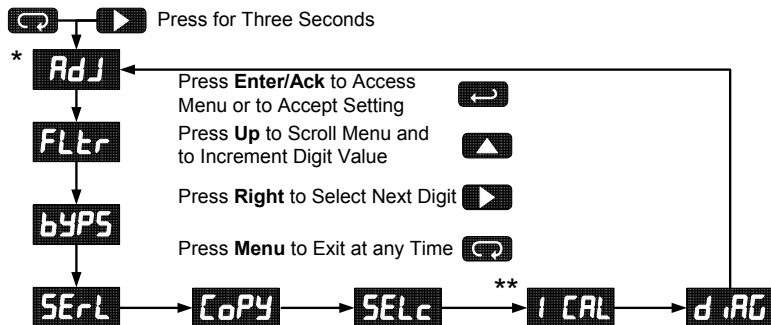

* Available for temperature inputs only

** Available for process inputs only

Advanced Features Menu & Display Messages

Display	Parameter	Action/Setting
<i>Adj</i>	<i>Adjust</i>	Set offset adjustment for temperature, not available for process inputs
<i>FLtr</i>	<i>Filter</i>	Set noise filter value
<i>bYP5</i>	<i>Bypass</i>	Set filter bypass value
<i>SErL</i>	<i>Serial</i>	Set serial communication parameters
<i>Prot</i>	<i>Protocol</i>	Enter the Protocol menu
<i>PdC</i>	<i>PDC</i>	Select PDC protocol
<i>m b5</i>	<i>Modbus</i>	Select Modbus protocol
<i>Addr</i>	<i>Address</i>	Set meter address
<i>BRud</i>	<i>Baud rate</i>	Select baud rate
<i>tr dE</i>	<i>Transmit delay</i>	Set transmit delay for serial communication
<i>Prty</i>	<i>Parity</i>	Select none, even, or odd (Modbus only)
<i>bytE</i>	<i>Byte-to-byte</i>	Program byte-to-byte timeout (silent time – Modbus only)
<i>CoPY</i>	<i>Copy</i>	Enter copy function
<i>SEnd</i>	<i>Send</i>	Send meter settings to another meter
<i>donE</i>	<i>Done</i>	Copy function completed
<i>SELc</i>	<i>Select</i>	Enter the Select menu (function, cutoff, out)
<i>Func</i>	<i>Function</i>	Select linear or square root function
<i>L inr</i>	<i>Linear</i>	Set meter for linear function
<i>SqrE</i>	<i>Square root</i>	Set meter for square root extraction
<i>cUtF</i>	<i>Cutoff</i>	Set low-flow cutoff
<i>out</i>	<i>Output</i>	Set meter for either relay or analog output (factory set only – corresponding option installed)
<i>IntY</i>	<i>Intensity</i>	Select display intensity
<i>Rout</i>	<i>Analog output</i>	Set meter for analog output option
<i>rELY</i>	<i>Relay</i>	Set meter for relay option
<i>iCAL</i>	<i>Initial calibration</i>	Enter initial calibration for process inputs

Display	Parameter	Action/Setting
<i>Curr</i>	<i>Current</i>	Calibrating current input
<i>I Lo</i>	<i>I low</i>	Calibrate low current input
<i>I Hi</i>	<i>I high</i>	Calibrate high current input
<i>Volt</i>	<i>Volt</i>	Calibrating voltage input
<i>vLo</i>	<i>V low</i>	Calibrate low voltage input
<i>vHi</i>	<i>V high</i>	Calibrate high voltage input
<i>d iRG</i>	<i>Diagnostics</i>	Display parameter settings
<i>LEd</i>	<i>LED</i>	Test display
<i>JC</i>	<i>CJC</i>	Display cold junction compensation voltage
<i>CFG</i>	<i>CFG</i>	Display meter configuration
<i>Pt5</i>	<i>Points</i>	Display calibration points for process inputs
<i>rELy</i>	<i>Relays</i>	Display relay settings
<i>Rout</i>	<i>Analog output</i>	Display analog output settings
<i>GOFF</i>	<i>Gain/offset</i>	Display gain and offset for process inputs
<i>SERL</i>	<i>Serial</i>	Display serial communication settings
<i>Info</i>	<i>Information</i>	Display software version and S/N information

For instructions on how to program numeric values see *Setting Numeric Values*, page 28.

Offset Adjustment (*RdJ*)

This parameter allows the user to select an offset adjustment to the temperature being displayed. Offset adjustment values can be either positive or negative and can be any number within $\pm 19.9^\circ$. The offset adjustment value is programmed through the *Adjust* menu.

The offset adjustment feature can be useful to compensate for errors due to thermocouple junctions or excessive lead wire resistance in RTDs.

The offset adjustment value is automatically reset to zero whenever the type of temperature sensor is changed (*i.e.* Thermocouple type or RTD curve).

Celsius/Fahrenheit conversion of the offset adjustment value is automatic, see note 2 below for important limitations.

Notes:

1. Offset adjustment is available only when TC or RTD input is selected.
2. If adjustment value is greater than 11°C and the temperature scale is changed to Fahrenheit, the maximum applied adjustment will be 19.9°F .

Noise Filter (*FLtr*)

Most applications do not require changing this parameter. It is intended to help attain a steady display with an unsteady (noisy) input signal.

The field selectable noise filter averages any minor or quick changes in the input signal and displays the reading with greater stability.

Increasing the filter value will help stabilize the display, however this will reduce the display response to changes on the input signal.

The filter level may be set anywhere from 2 to 199.

Setting filter value to zero disables filter function, and bypass setting becomes irrelevant.

Noise Filter Bypass (bYP5)

The meter can be programmed to filter small input changes, but allow larger input changes to be displayed immediately, by setting the bypass value accordingly.

If the input signal goes beyond the bypass value, it will be displayed immediately with no averaging done on it.

The noise filter bypass value may be set anywhere from 0.2 to 99.9. It corresponds to percentage of full scale for process inputs and to degrees Fahrenheit for temperature inputs.

Increasing the bypass value may slow down the display response to changes on the input signal.

Serial Communications (SErL)

The meter is equipped with serial communications capability as a standard feature using PDC Serial Communication Protocol. The Modbus RTU protocol is included on all models after 5/1/2010. To communicate with a computer or other data terminal equipment, an RS-232 or RS-485 adapter option is required, see *Ordering Information* on page 3 for details.

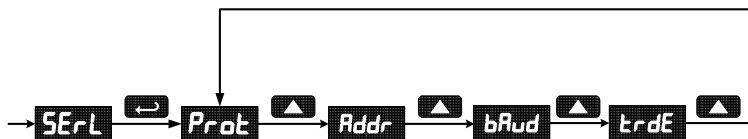

When using more than one meter in a multi-drop mode, each meter must be provided with its own unique address. The address may be programmed from 00 to 99 for PDC protocol and from 1 to 247 for Modbus protocol. The transmit delay may be set between 0 and 199 ms (see Serial Communication Adapter manual for more details).

The PRO can also be connected directly to another PRO meter through a cable assembly (PDA7420-PR). This allows the user to copy all the settings from one meter to another, using the *Copy* function.

Protocol Selection Menu (Prot)

The Protocol selection menu is used to select either the PDC or the Modbus protocol.

Select Menu (SELC)

The *Select* menu is used to select linear or square root function, display intensity, and low-flow cutoff. Selection for relay or analog output is a factory setting depending on the option installed.

- Output options are installed and set up at the factory.
- Changing the output selection will cause erroneous operation.

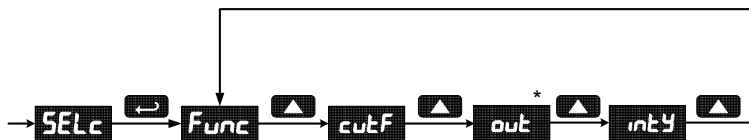

*The *Output* selection menu is for factory use only
Do not change output selection!

Linear or Square Root Function (L inr or Sqrt)

Meters are set up at the factory for linear function. The linear function provides a display that is linear with respect to the input signal.

The square root function is used to linearize the signal from a differential pressure transmitter and display flow rate in engineering units.

Advanced
Features

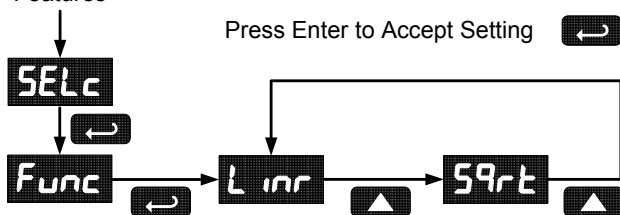

Low-Flow Cutoff (cutF)

The low-flow cutoff feature allows the meter to be programmed so that the often-unsteady output from a differential pressure transmitter, at low flow rates, always displays zero on the meter.

The cutoff value may be programmed from 0 to 9999. Below the cutoff value, the meter will display zero. Programming the cutoff value to zero disables the cutoff.

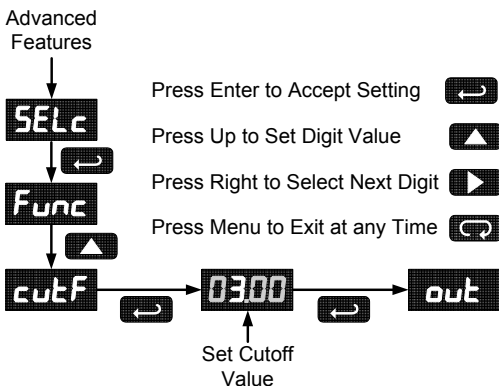

Display Intensity (intY)

The Display Intensity function allows the selection of eight levels of intensity for various lighting conditions.

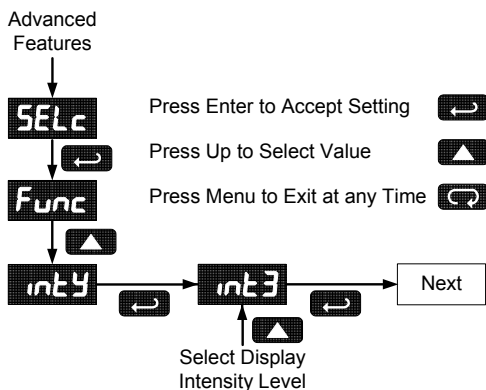

MeterView® Software

MeterView® software allows the PRO to be programmed from a PC and to act as a data logger.

MeterView® software allows all setup parameters to be saved to a file for reporting, restoring, or programming other meters.

See *Ordering Information*, page 3 to order MeterView® software.

Note: PDC protocol must be selected to communicate with MeterView®.

Meter Copy Function (COPY)

The Copy function is used to copy (or clone) all the settings from one meter to other meters requiring exactly the same setup and programming (*i.e.* type of input, scaling, decimal point, filter, bypass, etc.).

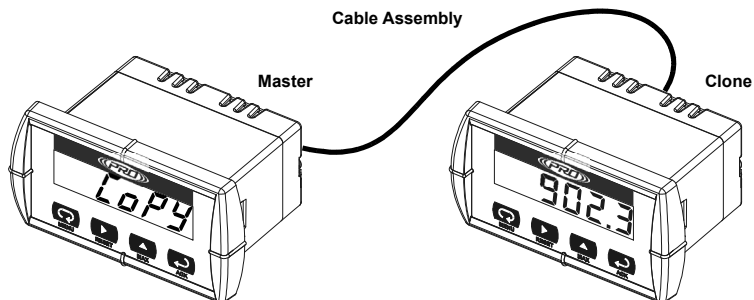

Figure 16. Meter Copy Connection

Copy Function Requirements

To successfully copy settings from one meter to another, both meters must have:

1. Same software version
2. Same baud rate setting
3. PDC protocol selected

See *Determining Software Version*, page 65 for instructions.

Meter Cloning Instructions

NOTICE! *Do not connect the two meters to the same 4-20 mA loop while cloning. Internal calibration may be affected.*

1. Connect the two meters using cable assembly PDA7420-PR or equivalent (e.g. Digi-Key P/N H1663-07-ND). Cable should not exceed 7' (2.1 m).
2. Power up both meters. Leave Clone meter in Run Mode.
3. Enter the *Advanced* features menu of the Master meter, see *Advanced Features Menu*, page 50.
4. Scroll to *Copy* function using **Up** arrow button then press **Enter/Ack**.
5. The meter displays the message *SEnd*. Press **Enter/Ack**, the display flashes while sending data. The message *donE* is displayed when copying is completed.

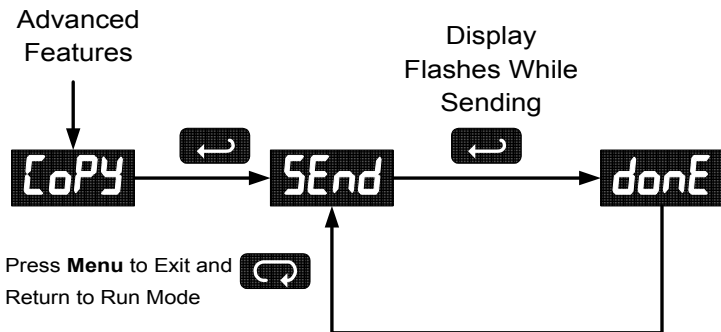

6. The Clone meter displays the memory address being programmed then the message *donE* when copying is completed. The meter initializes and returns to Run Mode using the same settings as the Master.
7. If meter to be cloned does not respond to the data being sent, refer to **Copy Function Requirements** above.

Internal Calibration (iCAL)

- There is **no need to recalibrate** the meter when first received from the factory.
- The meter is **factory calibrated** prior to shipment, for all input types, in milliamps, volts, and degrees respectively. The calibration equipment is certified to NIST standards.

The internal calibration allows the user to scale the meter without applying a signal. This menu is not available if the meter is set up for TC or RTD inputs.

The use of calibrated signal sources is necessary to perform the internal calibration of the meter.

Check calibration of the meter at least every 12 months. Each input type must be recalibrated separately, if meter will be used with all input types.

Notes:

- If meter is in operation and it is intended to accept only one input type (e.g. 4-20 mA), recalibration of other inputs is not necessary.
- Allow the meter to warm up for at least 15 minutes before performing the internal calibration procedure.

The *Internal calibration* menu is part of the *Advanced* features menu.

1. Press and hold the **Right** arrow and the **Menu** buttons, for three seconds, to access the Advanced features of the meter (Press and hold Right **arrow** first then Menu).
2. Press the **Up** arrow button to scroll to the *Internal calibration* menu and press **Enter/Ack**.
3. The meter displays either current (*CURR*) or voltage (*VOLT*), according to the meter input setup. Press **Enter/Ack** to start the calibration process.

Example for current input internal calibration:

4. The meter displays *Low* input current (*I Lo*). Apply the low input signal and press **Enter/Ack**. The display flashes for a moment while meter is accepting the low input.
5. After the display stops flashing, a number is displayed with the leftmost digit brighter than the rest. The bright digit is the active digit that can be changed by pressing the **Up** arrow button. Press the **Right** arrow button to move to the next digit.
6. Set the display value to correspond to the input signal being calibrated.
7. The display moves to the high input calibration (*I Hi*). Apply the high input signal and press **Enter/Ack**.
8. Set the display for the high input calibration in the same way as it was set for the low input calibration.

For instructions on how to program numeric values see *Setting Numeric Values*, page 28.

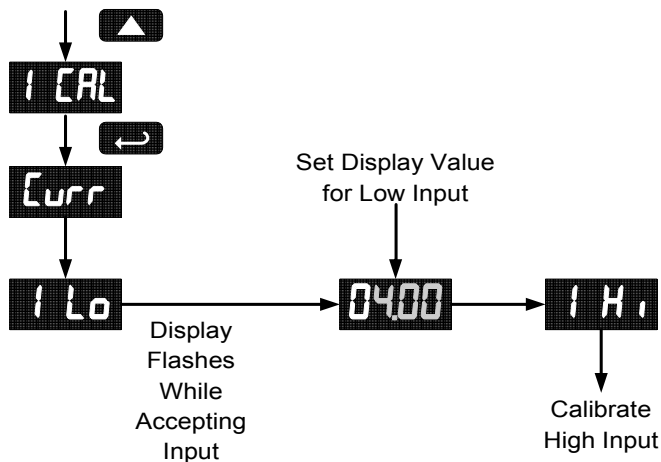

The graphic above shows the calibration of the current input. The voltage input is calibrated in a similar way.

Tips:

- Low and high input signals can be any valid values within the range of the meter.
- Observe minimum input span requirements between input 1 and input 2.
- Low input must be less than high input signal.

Error Message (*Err*)

An error message indicates that the calibration or scaling process was not successful.

After the error message is displayed, the meter reverts to input 1, allowing the appropriate input signals to be applied.

The error message might be caused by any of the following conditions:

1. Input signal is not connected to the proper terminals, or it is connected backwards.
2. Wrong signal selection in *Setup* menu.
3. Minimum input span requirements not maintained.

Minimum Input Span

The minimum input span is the minimum difference between input 1 and input 2 signals required to complete the calibration or scaling of the meter.





Input range	Input 1 & input 2 span
4-20 mA	0.40 mA
±10 VDC	0.20 VDC

OPERATION

For process inputs, the meter is capable of accepting positive and negative signals and displaying these signals in engineering units from -1999 to 9999 (e.g. a signal from -10 to +10 VDC could be displayed as -10.00 to 10.00).

The temperature inputs are displayed according to the input type and temperature units (°F or °C) selected. Type T thermocouples can be displayed with either 1° or 0.1° resolution.

Front Panel Buttons Operation

Button Symbol	Description
	Press to enter or exit Programming Mode, view settings, or exit Max/Min readings
	Press to reset Max/Min readings
	Press to display Max/Min readings alternately
	Press to display Max/Min reading indefinitely while displaying Max/Min Press ACK to acknowledge relays

Maximum/Minimum Readings

The main function of the front panel buttons during operation is to display the maximum and minimum readings reached by the process or temperature inputs.

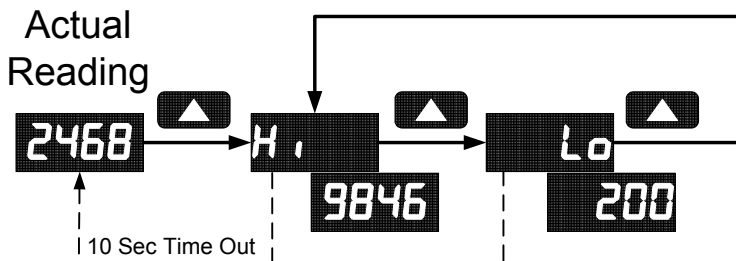

Press **Up** to Display and to
Toggle Between Max & Min



Press **Enter** to Hold Max/Min



Press **Right** to Reset Max/Min



Press **Menu** to Exit Max/Min



1. Press **Up** arrow/**Max** button to display maximum reading since the last reset/power-up.
2. Press **Up** arrow/**Max** again to display the minimum reading since the last reset/power-up.
3. Press **Enter/Ack** to hold Max/Min display reading, the meter will continue to track new Max/Min readings.
4. If **Enter/Ack** is not pressed, the Max/Min display reading will time out after ten seconds and the meter will return to display the actual reading.
5. Press **Right** arrow/**Reset** button to reset Max/Min while reading is being displayed. Max/Min display readings are reset to actual reading.

MOUNTING DIMENSIONS

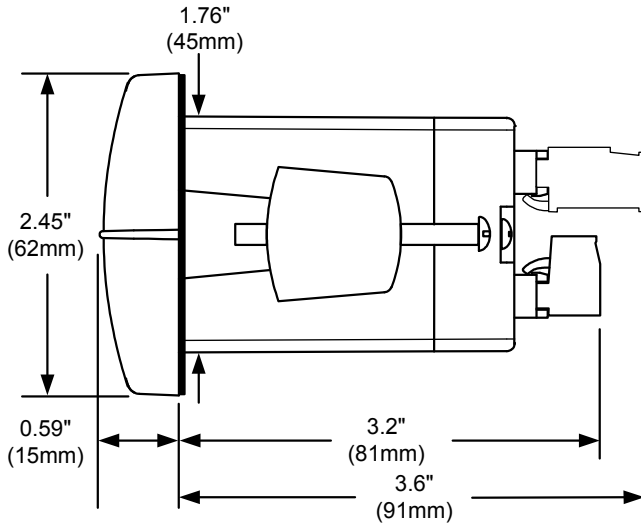

Figure 17. Meter Dimensions – Side View

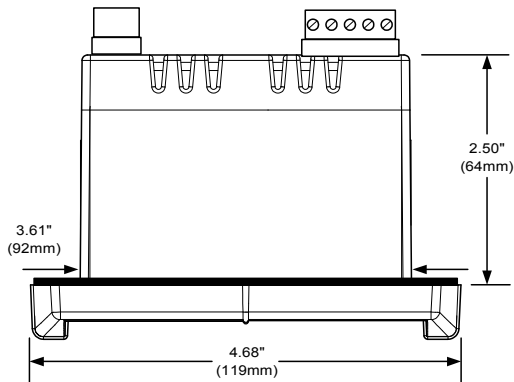

Figure 18. Case Dimensions - Top View

TROUBLESHOOTING

The rugged design and the user-friendly interface of the meter should make it unusual for the installer or operator to refer to this section of the manual.

If the meter is not working as expected, refer to the *Diagnostics* menu and recommendations below.

Diagnostics Menu (d iRG)

The *Diagnostics* menu is located in the *Advanced* features menu, to access *Diagnostics* menu see *Advanced Features Menu*, page 50.

It provides an easy way to view the programmed parameter settings for troubleshooting purposes. Press the **Enter/Ack** button to view the settings and the **Menu** button to exit at any time.

For a description of the diagnostics messages see *Advanced Features Menu & Display Messages*, page 51.

Determining Software Version

To determine the software version of a meter:

1. Go to the *Diagnostics* menu (d iRG) and press **Enter/Ack** button.
2. Press **Up** arrow/**Max** button and scroll to Information menu (inFa).
3. Press **Enter/Ack** to access the software number (5Ft), version (UER). Write down the information as it is displayed. Continue pressing **Enter/Ack** until all the information is displayed.

Reset Meter to Factory Defaults

When the parameters have been changed in a way that is difficult to determine what's happening, it might be better to start the setup process from the factory defaults.

Instructions to load factory defaults:

1. Enter the *Advanced* features menu. See *Advanced Features Menu*, page 50.
2. Press **Up** arrow to go to *Diagnostics* menu
3. Press and hold **Right** arrow/Reset for five seconds, press **Enter/Ack** when display flashes *rESEt*.
Note: If **Enter/Ack** is not pressed within three seconds, display returns to *Diagnostics* menu.
4. The meter goes through an initialization sequence (same as on power-up), and loads the factory default settings.

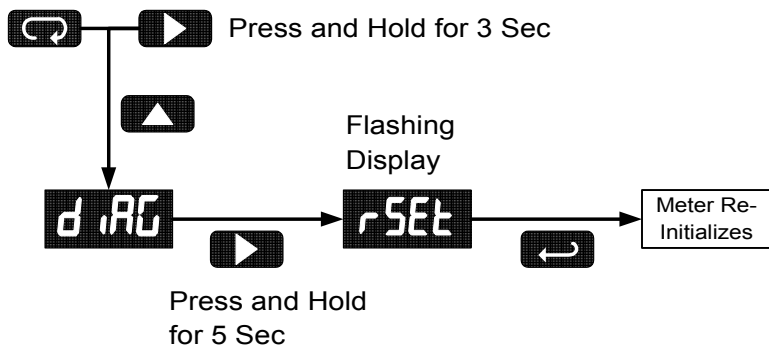

Factory Defaults & User Settings

The following table shows the factory setting for most of the programmable parameters on the meter. Next to the factory setting, the user may record the new setting for the particular application. MeterView[®] software allows the saving of all meter parameters to a file for restoring meter settings, reporting, and copying settings to other meters.

Model: _____ S/N: _____ Date: _____

Parameter	Display	Default Setting	User Setting
<i>Input type</i>	INPt	4-20 mA	
<i>Programming</i>	PROG	Scale	
<i>Input 1</i>	INP 1	4.00 mA	
<i>Display 1</i>	d 1S 1	4.00	
<i>Input 2</i>	INP2	20.00 mA	
<i>Display 2</i>	d 1S2	20.00	
<i>Decimal point</i>	dddd	2 places	
<i>Relay 1</i>	rLY 1		
<i>Action 1</i>	Act 1	Automatic	
<i>Set 1</i>	SEt 1	7.00	
<i>Reset 1</i>	rSEt 1	6.00	
<i>Relay 2</i>	rLY2		
<i>Action 2</i>	Act2	Automatic	
<i>Set 2</i>	SEt2	10.00	
<i>Reset 2</i>	rSEt2	9.00	
<i>Fail-safe</i>	FLSF		
<i>Fail-safe 1</i>	FLS 1	Off	
<i>Fail-safe 2</i>	FLS2	Off	
<i>Time delay</i>	dLAY		
<i>On delay 1</i>	On 1	0 sec	
<i>Off delay 1</i>	OFF 1	0 sec	
<i>On delay 2</i>	On2	0 sec	
<i>Off delay 2</i>	OFF2	0 sec	

Parameter	Display	Default Setting	User Setting
<i>Password</i>	PRSS	0000 (unlocked)	
<i>Advanced Features</i>			
<i>Adjust</i>	AdJ	0.0° (temp only)	
<i>Filter</i>	FLtr	10	
<i>Bypass</i>	bYPS	0.2	
<i>Serial settings</i>			
<i>Protocol</i>	PdC	PDC protocol	
<i>Address</i>	Rddr	00	
<i>Baud rate</i>	bRud	2400	
<i>Trans delay</i>	trdE	10 ms	
<i>Function</i>	Func	Linear	
<i>Cutoff value</i>	CuF	0.00 (disabled)	
<i>Output option</i>	out	Factory set only	
<i>Display intensity</i>	intY	Level 2	
<i>Modbus defaults</i>			
<i>Address</i>	Rddr	247	
<i>Parity</i>	Prty	Even	
<i>Byte-to-byte timeout*</i>	tbYt	0.01 sec	

***Note:**

The byte-to-byte timeout setting might be updated automatically depending on the baud rate selected and the previous timeout setting. The minimum timeout allowed is saved to memory if a lower value is entered (e.g. If user enters 0.00 with a baud rate of 300, 0.06 is saved).

Troubleshooting Tips

Symptom	Check/Action
No display at all	Check power at power connector
Not able to change setup or programming, $L\alpha Ld$ is displayed	Meter is locked, enter correct four-digit password to unlock
Meter displays error message during calibration (Err)	Check: <ol style="list-style-type: none"> 1. Signal connections 2. Input selected in <i>Setup</i> menu 3. Minimum input span requirements
Meter displays <ul style="list-style-type: none"> • αPEn • 9999 • -1999 • Displays negative number, not responding to RTD. 	Check: <ol style="list-style-type: none"> 1. Input selected in <i>Setup</i> menu 2. TC/RTD Switch position 3. Corresponding signal at Signal connector
Display alternates between <ol style="list-style-type: none"> 1. H and a number 2. $L\alpha$ and a number 	Press Menu to exit Max/Min display readings.
Display response is too slow	Check filter and bypass values
Inaccurate temperature reading	Check: <ol style="list-style-type: none"> 1. Temperature units ($^{\circ}F$ or $^{\circ}C$) 2. TC type or RTD curve selected 3. Offset adjustment 4. TC wire used 5. Calibration
If the display locks up or the meter does not respond at all	Cycle the power to restart the microprocessor.
Relay operation is reversed	Check: <ol style="list-style-type: none"> 1. Fail-safe in <i>Setup</i> menu 2. Wiring of relay contacts
Relay and status LED do not respond to signal	Check: <ol style="list-style-type: none"> 1. Relay action in <i>Setup</i> menu 2. Set and reset points
Meter not communicating with MeterView [®] or other programs	Check: <ol style="list-style-type: none"> 1. Serial adapter and cable 2. Serial protocol selected 3. Meter address and baud rate 4. MeterView address and baud rate
Other symptoms not described above	Call Technical Support for assistance.

QUICK USER INTERFACE REFERENCE GUIDE

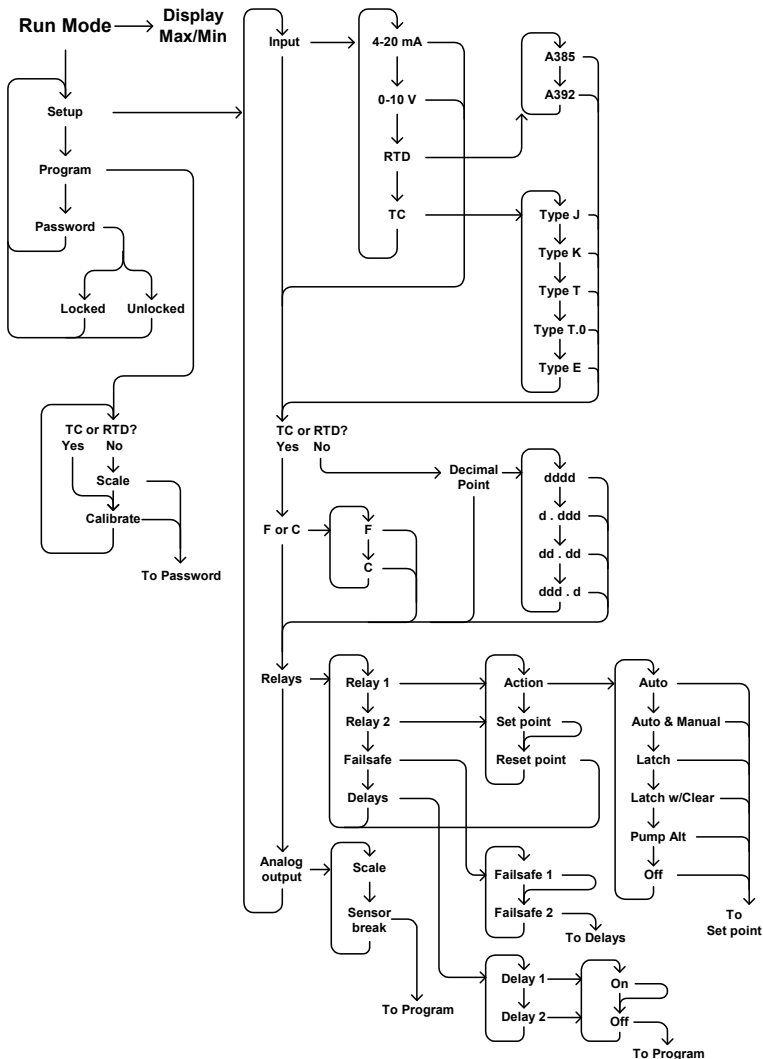

Pushbutton	Function
Menu	Go to Programming Mode or leave Programming, Advanced Features, and Max/Min Modes.
Right Arrow	Move to next digit.
Up Arrow	Move to next selection or increment digit.
Enter/Ack	Accept selection/value and move to next selection.

Right Arrow & Menu held for 3 seconds enters Advanced Features

Max/Min Mode

While in Run Mode, pressing **Up Arrow** will initiate Max/Min Mode. **Up Arrow** toggles between Max & Min displays, and **Right Arrow** resets the Max/Min to the current value. Press **Menu** or wait 10 seconds to return to Run Mode. Pressing **Enter/Ack** will disable the 10 second timeout and continuously display Max or Min.

Press & hold **Right** arrow and **Menu** for 3 seconds to access Advanced Features Menu

When the meter is locked, Adjust, Filter and Bypass can only display their settings, and the Copy and ICAL functions are not available.

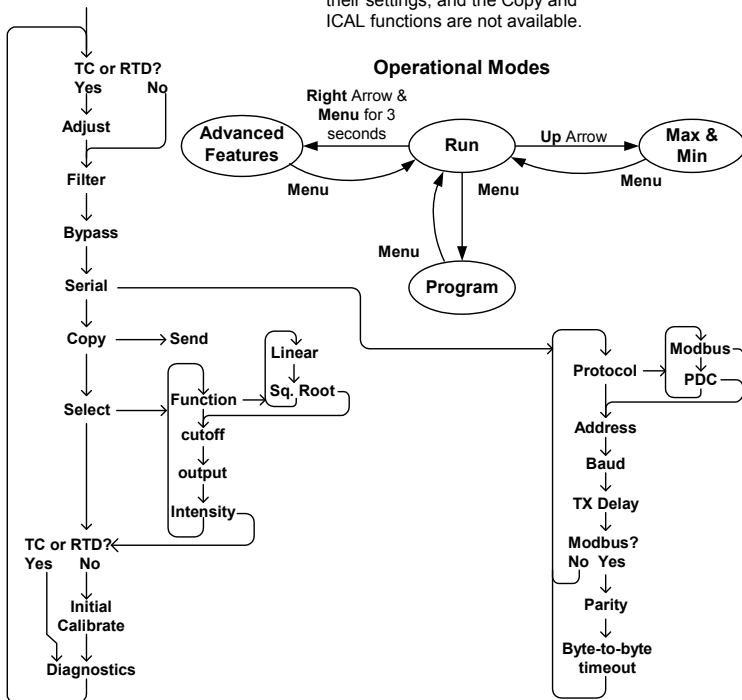

How to Contact CTC

- For Technical Support please
Call: 1-800-999-5290 (US & Canada)
1-585-924-5900 (International)
Email: sales@ctconline.com
- For Sales Support or to place an order please
Call: 1-800-999-5290 (US & Canada)
1-585-924-5900 (International)
Email: sales@ctconline.com
- For the latest version of this manual please visit
www.ctconline.com

