



CONNECTION TECHNOLOGY CENTER, INC.

LEVEL 2 – LESSON 2

FREQUENCY RESPONSE AND MOUNTED RESONANCE FOR ACCELEROMETERS: A BASIC UNDERSTANDING



INTRODUCTION

Welcome to **Level 2, Lesson 2** of CTC's free online vibration analysis training. We're glad you have taken the time to view this self-paced lesson on Frequency Response and Mounted Resonance for Accelerometers. We hope you enjoy the training and will continue to build your vibration analysis knowledge as you progress through Level 2.

'Frequency Response and Mounted Resonance for Accelerometers: A Basic Understanding' is created and presented by CTC for complimentary educational use only. This training presentation may not be edited or used for any other purposes without express written consent from CTC.



OBJECTIVES

After completing this training module you will understand the concepts of:

- Natural Frequency**
- Frequency Response**
- Resonance**
- Mounted Resonance**

You will also learn how each of the above concepts affect the data used for vibration analysis and condition monitoring.

Better understanding these principles will enable you to make sure that you are not missing important data, and will ultimately assist you in making better "calls."



FREQUENCY RESPONSE - TERMS

Every object or system has a **Natural Frequency** – the frequency or set of frequencies at which an object or system will vibrate when struck, set in motion, or disturbed. The natural frequency of an object or system is independent upon the stiffness and mass of that object or system.

When an object or system is excited at its natural frequency, the result is a greatly amplified vibration. This is known as **Resonance**.

The natural frequency of an accelerometer or velocity sensor is typically listed as the **Resonant Frequency** on the sensor's datasheet.

The natural or resonant frequency of a sensor will have a direct effect on that sensor's **Frequency Response** – a sensor's ability to measure the correct amplitude of a vibration at a given frequency. A sensor's data sheet will typically list a sensor's frequency response in relation to the minimum or maximum frequencies that the sensor can measure to a given degree of accuracy.

| Specifications | Standard | Metric |
|---------------------------|-----------------|--------------|
| Part Number | AC210 | M/AC210 |
| Sensitivity (±5%) | | 100 mV/g |
| Frequency Response (±3dB) | 30-900,000 CPM | 0,5-15000 Hz |
| Frequency Response (±10%) | 60-420,000 CPM | 1,0-7000 Hz |
| Frequency Response (±5%) | 120-240,000 CPM | 2,0-4000 Hz |

| | | |
|--------------------|-----------------|---------------|
| Resonant Frequency | 1,560,000 CPM | 26000 Hz |
| Mounting Torque | 2 to 5 ft. lbs. | 2,7 to 6,8 Nm |

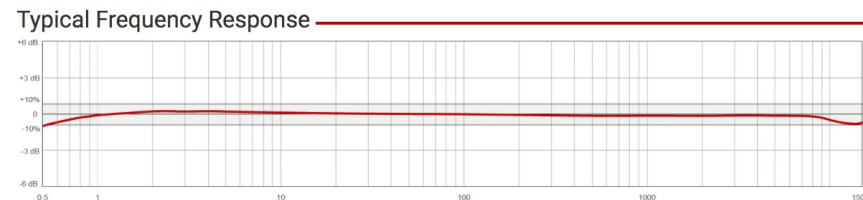

AC210 Series
Premium Accelerometer, Top Exit Connector / Cable, 100 mV/g



- Product Features**
- High Performance Sensor for Demanding Applications
 - High Dynamic Range with Excellent Frequency Response
 - ±80 g, Dynamic Range
 - Excellent Bias Stability throughout operating temperature range
 - 100 mV/g ±5%

| AC210-1D | AC210-2D | AC210-3D | AC210-6D |
|---|---|---|--|
| 2 Pin Connector C9303 Integral Cable | 2 Pin Connector C9303 Integral Cable | 3 Pin Connector C9306 Armored Integral Cable | 6 Pin Connector C9311 Heavy Duty Armored Integral Cable |
| Stock Product | Built To Order | Built To Order | Built To Order |

| Specifications | Standard | Metric | Specifications | Standard | Metric |
|-----------------------------|-----------------|--------------|-----------------------------|----------------------|------------------|
| Part Number | AC210 | M/AC210 | Environment | | |
| Sensitivity (±5%) | | 100 mV/g | Temperature Range | 58 to 250°F | 50 to 121°C |
| Frequency Response (±3dB) | 30-900,000 CPM | 0,5-15000 Hz | Maximum Shock Protection | 5,000 g peak | |
| Frequency Response (±10%) | 60-420,000 CPM | 1,0-7000 Hz | Electromagnetic Sensitivity | CE | |
| Frequency Response (±5%) | 120-240,000 CPM | 2,0-4000 Hz | Sealing | Wetted, Hermetic | |
| Dynamic Range | | ± 80 g, peak | Submersible Depth | 200 ft. | 60 m |
| Startup Time | | <2.5 seconds | Physical | | |
| Voltage Source (VDC) | | 18-30 VDC | Sensing Element | PZT Ceramic | |
| Constant Current Excitation | | 2-30 mA | Sensing Structure | Shear Mode | |
| Spectral Noise @ 10 Hz | | 8 µg/√Hz | WEAR | 3.2 µin | 80 grams |
| Spectral Noise @ 100 Hz | | 4 µg/√Hz | Case Material | 316L Stainless Steel | |
| Spectral Noise @ 1000 Hz | | 2 µg/√Hz | Mounting | | |
| Output Impedance | | <100 ohms | Connector (Non-Integral) | 2 Pin MIL-C-5015 | 26000 Hz |
| Input Voltage | | 18-30 VDC | Resonant Frequency | 1,560,000 CPM | 27 to 6.8 Nm |
| Self-Relaxation | | >100 ohms | Mounting Torque | 2 to 5 ft. lbs. | |
| | | | Mounting Hardware | 1/4-28 Stud | MSA Adapter Stud |
| | | | Calibration Certificate | GA10 | |

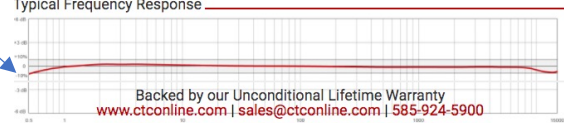

Backed by our Unconditional Lifetime Warranty
www.ctconline.com | sales@ctconline.com | 585-924-5900



FREQUENCY RESPONSE – MASS AND STIFFNESS

Mass and **stiffness** play a key role in defining the natural frequency.

The natural frequency F_n is equal to:
 $1/(2\pi)$ x the square route of the stiffness (K)
divided by the mass (M)

Mass (M) can be expressed as the **weight (W)**
divided by **gravity (g)**.

If the **stiffness decreases**, the **natural frequency will also decrease** (direct relationship).

If the **mass (weight) increases**, the **natural frequency will decrease** (inverse relationship).

$$F_n = 1/(2\pi) \sqrt{k/m} \text{ where:}$$

- F_n = Natural Frequency (Hz)
- k = Stiffness
- m = Mass
- m = weight / gravity

- As **stiffness increases**,
the **natural frequency increases**
- As **mass increases**,
the **natural frequency decreases**



FREQUENCY RESPONSE – EXAMPLE OF STIFFNESS AND NATURAL FREQUENCY

A simple example of the effects of stiffness on natural frequency is a guitar string, which when plucked will resonate at its natural frequency. When that string is tightened, stiffness is added to the system of the string, bridge and key, the natural frequency increases and the note you hear is higher pitch.

Now let's look at a fan which is mounted to a frame. **When the fan is run at the frame's natural frequency, the fan will resonate.** Unlike a guitar string, achieving resonance on a large fan is not desirable. An analyst may recommend that the frame of the fan receive additional structural support, thus stiffening the system and raising the natural frequency beyond the running speed of the fan, so that the fan does not "go into resonance" under normal operating conditions.

These same principles are at work in an accelerometer. Your sensor is designed to maximize stiffness and minimize mass to achieve a desired resonant frequency and frequency range.

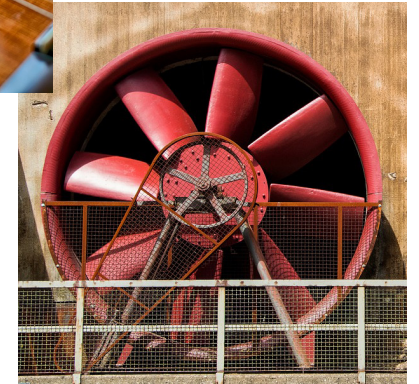

FREQUENCY RESPONSE – WHAT IS IT?

As discussed previously, **frequency response is a sensor's ability to measure the correct amplitude of a vibration at any frequency.**

In other words, 1 g input at 1 Hz should yield 1 g output from the sensor at 1 Hz; just as 1 g input at 1000 Hz should produce a 1 g output from the sensor at 1000 Hz, and so on.



FREQUENCY RESPONSE – IN THE REAL WORLD

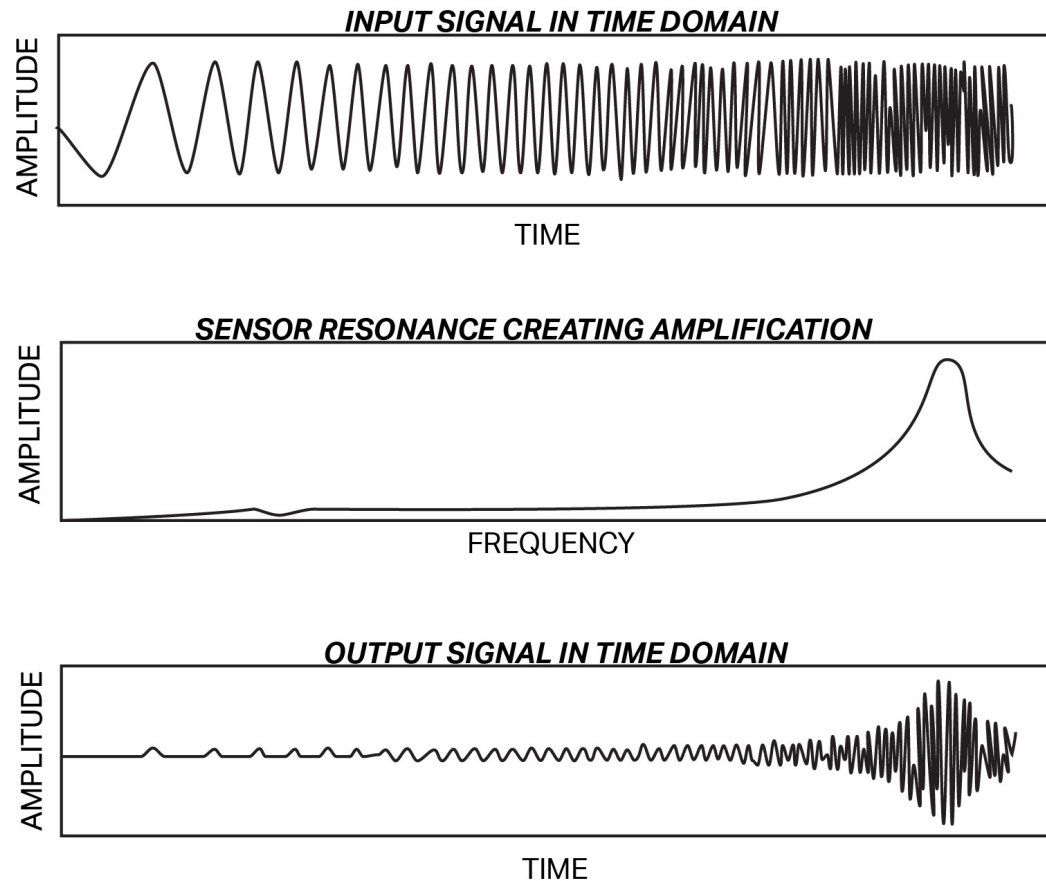

Unfortunately, in the real world, the frequency response is not always flat!

In the **upper plot**, the input signal in the time domain has equal amplitudes although the frequency increases.

The frequency response of the sensor always has limitations. The **center plot** shows sensor resonance creating amplification.

If the sensor illustrated in the center plot is used to measure the signal illustrated in the upper plot, the output signal in the time domain is modified as a result of resonance, and amplification occurs as shown in **the bottom plot**.

FREQUENCY RESPONSE – LOW FREQUENCY

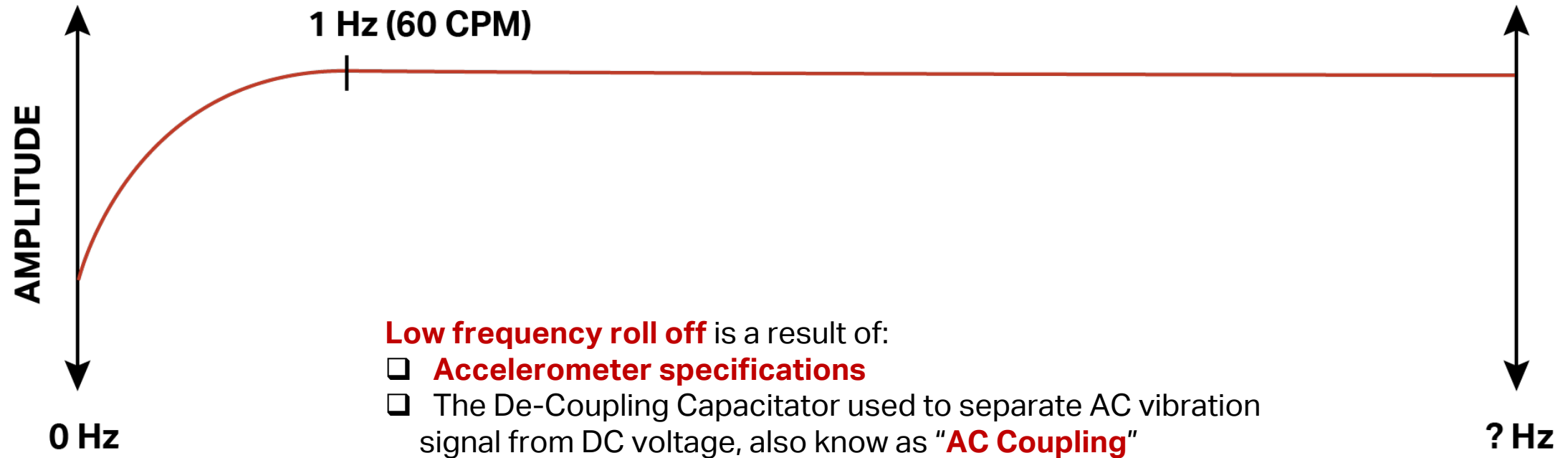

Low frequency roll off is typically a factor at less than 1 Hz (60 CPM)

FREQUENCY RESPONSE – HIGH FREQUENCY

High frequency gain is a result of:

- Accelerometer specifications and resonance**
- Mounted resonance**

*High frequency gain is typically only a factor at 500 Hz (30,000 CPM) and greater, and **is highly dependent on mounting method!***

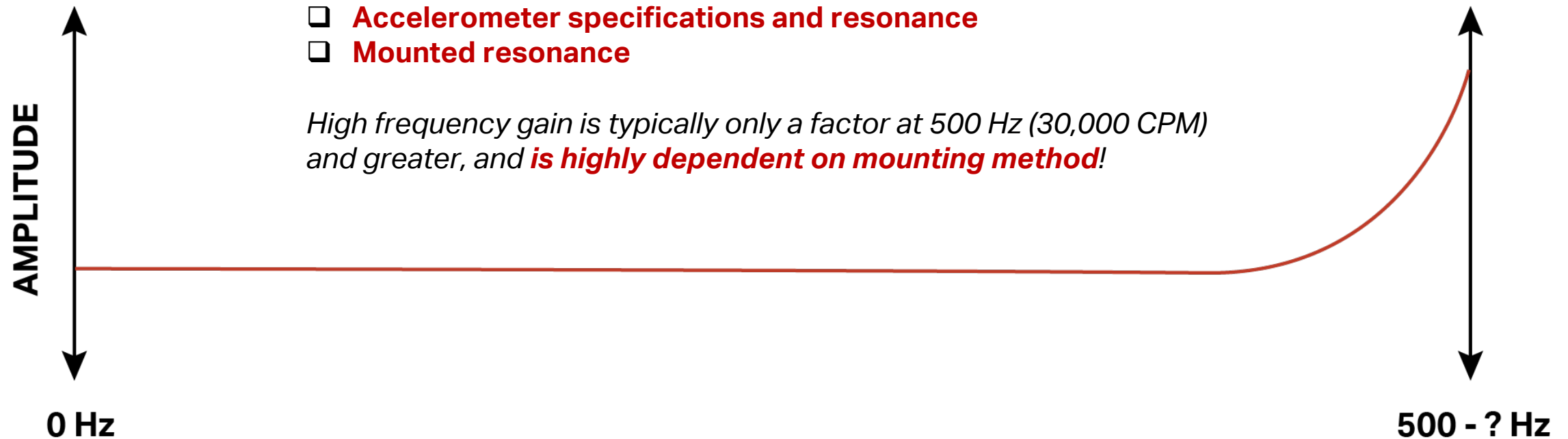

MOUNTED RESONANCE – WHAT IS IT?

As noted earlier, **resonance** is the result of operating a machine, sensor, or accelerometer at its natural frequency

Mounted resonance is the resulting change in natural frequency, caused by the structural change of the accelerometer, based on the mounting method used. This change in natural frequency is a direct result of the change in mass and stiffness.

Several things can happen at resonance:

- Large gains in amplitude
- Errors in signal amplitude
- Phase change $\approx 180^\circ$
- Destructive forces can occur



MOUNTED RESONANCE – TRANSMISSION, AMPLIFICATION, ISOLATION

There are three regions of a typical accelerometer response curve!

❑ TRANSMISSION

The **transmission** region is defined as the usable region of the accelerometer, and will be specified at + / - 5%, + / - 10%, or + / - 3dB.

❑ AMPLIFICATION

The **amplification** region is defined as the area in which resonance is occurring and creating significant signal gain. Measurements in the amplification region should be taken with care using special programs provided by the data collector manufacturers.

❑ ISOLATION

The **isolation** region is defined as the area above resonance that has unpredictable gain, phase and amplitude. The **isolation region should never be used for measurements.**



MOUNTED RESONANCE – TRANSMISSION, AMPLIFICATION, ISOLATION

This is a graphical representation of the three regions of an accelerometer response curve as explained in the previous slide – **transmission**, **amplification**, and **isolation**.

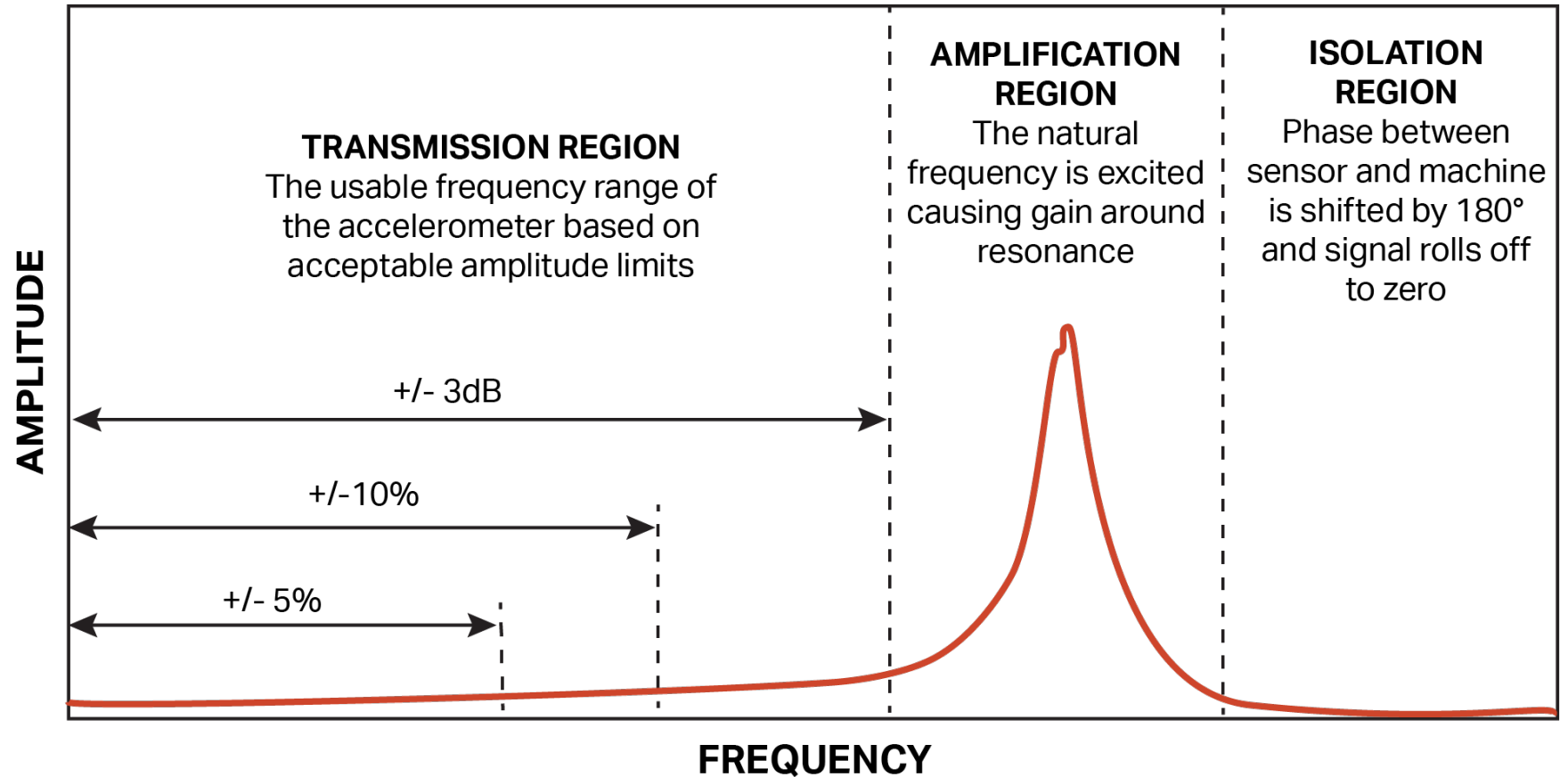

MOUNTED RESONANCE – RESONANCE CHANGES AND MOUNTING



The mounting method used for an accelerometer can affect mounted resonance. **Mounted resonance can in turn effect:**

- ❑ **Transmission, amplification** and **isolation range** of the sensor
- ❑ **Frequency response** of the sensor



Therefore, analysts using mounting methods other than the standard stud mount must consider what effect the new mounted resonance and new frequency range will have on the data being collected.

MOUNTED RESONANCE – TYPICAL MOUNTING METHODS

Let's take a look at **six typical mounting methods** for an accelerometer.

Remember, each of these methods is very useful, but they can all have an effect on the frequency response of the accelerometer.

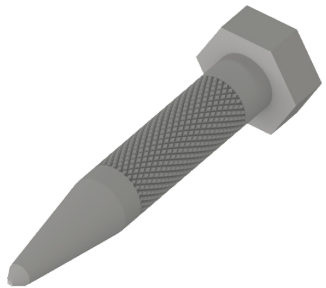

**PROBE
TIP**

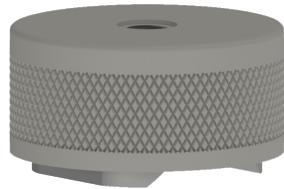

**CURVED SURFACE
MAGNET**

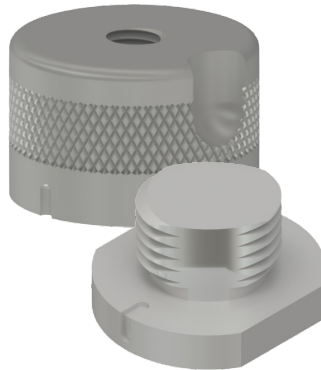

**QUICK
DISCONNECT**



**FLAT MAGNET
WITH TARGET**



**ADHESIVE
MOUNT**



**STUD
MOUNT**

MOUNTED RESONANCE – TYPICAL CHANGES IN RESPONSE

The following are the changes in frequency response of the accelerometer based on +/- 3dB limits using the six typical mounting methods.

Notice that the mounting method can limit the frequency response.

Be careful when choosing the mounting method for your sensor. Don't miss valuable data!

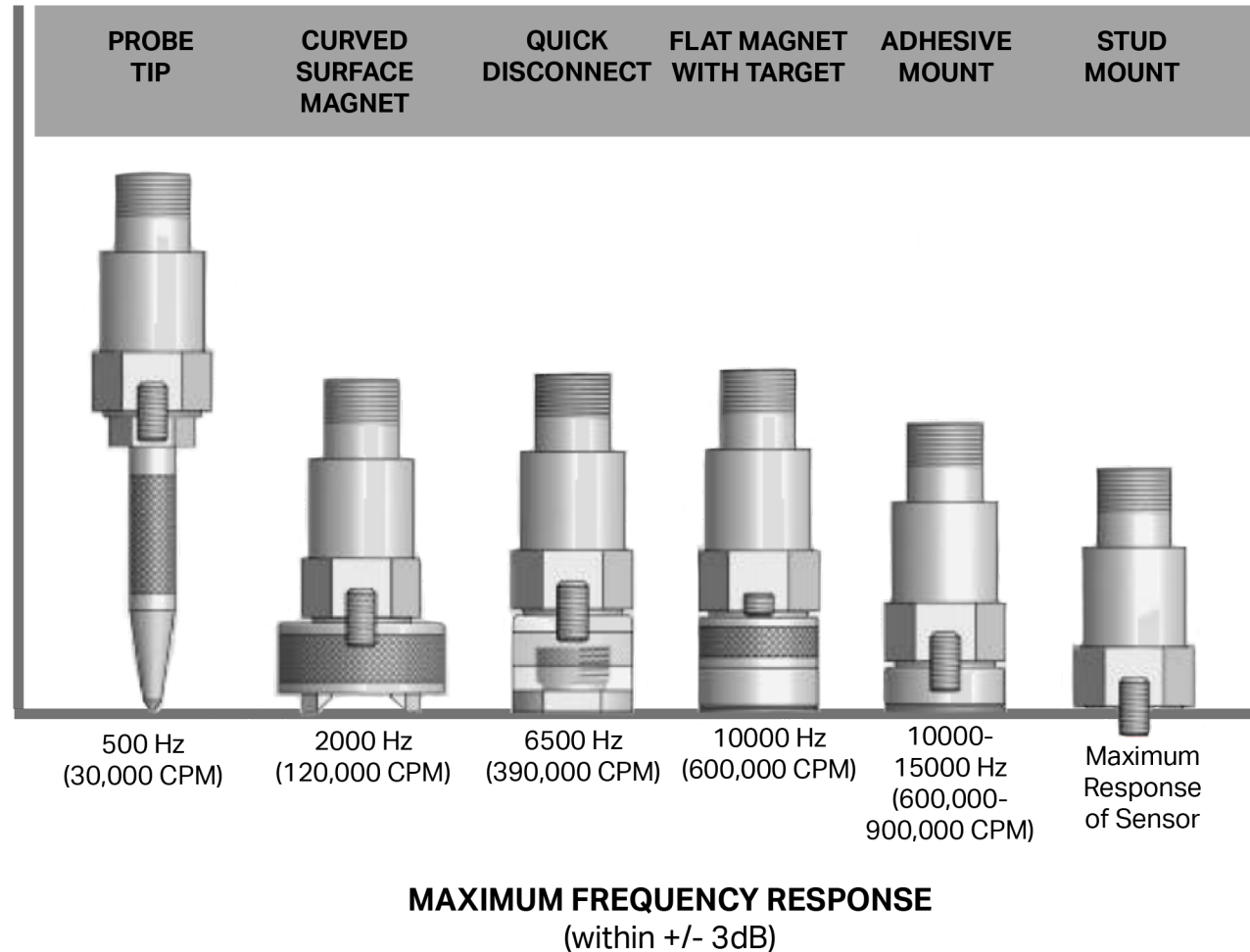

MOUNTED RESONANCE – TYPICAL CHANGES IN RESPONSE

The **probe tip**, or “stinger,” has the least amount of surface area contact and the least consistent and reliable pressure to fix the probe to the machinery. These factors all effect the stiffness of the mounting. The probe itself also adds mass to the sensor. The result is dramatically lower mounted resonance which reduces the effective high frequency response (at 3dB) to just 500 Hz (30,000 CPM).

The conclusion is that analysts looking for critical data above 500 Hz should opt for a different method of mounting their accelerometer.

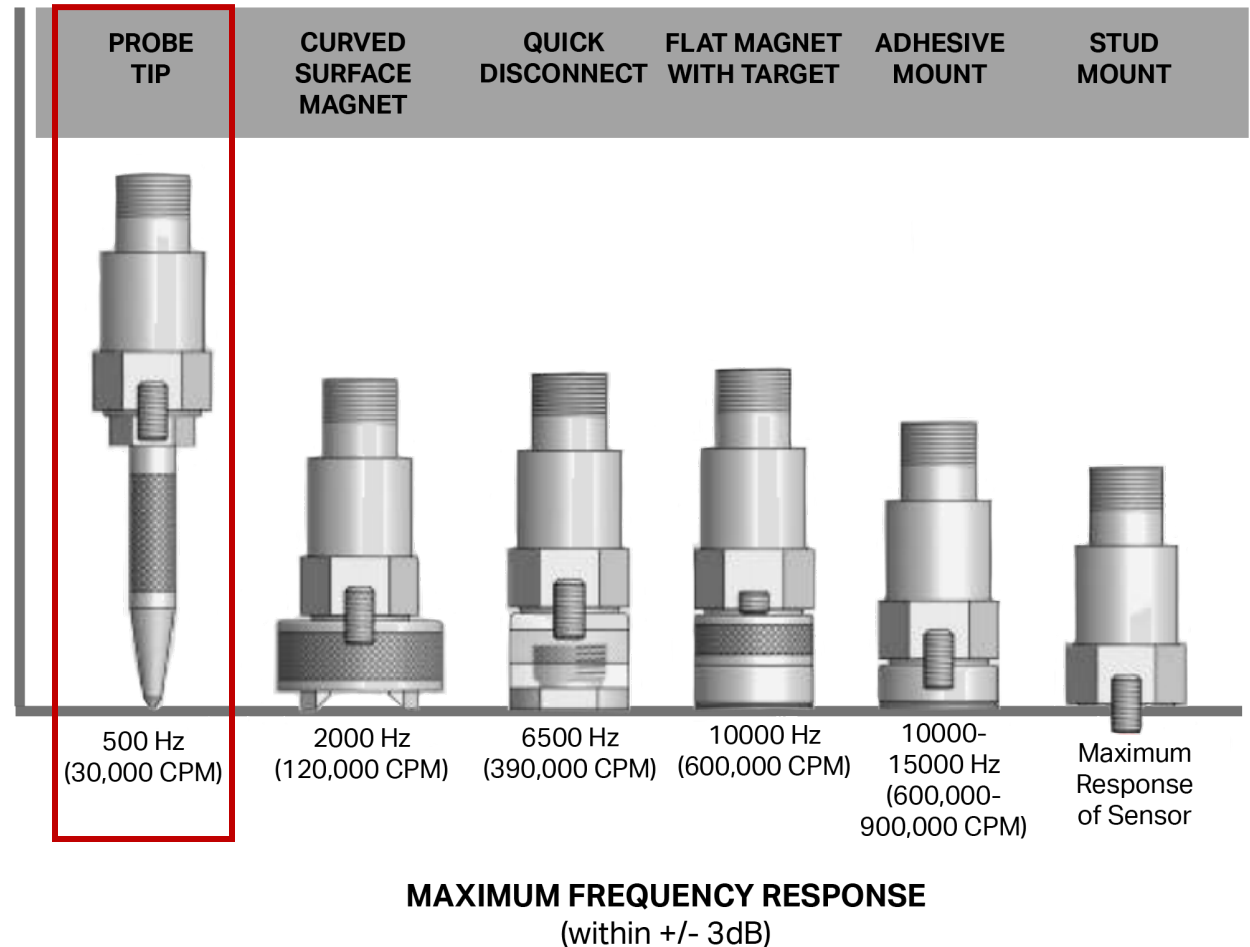

MOUNTED RESONANCE – TYPICAL CHANGES IN RESPONSE

The **curved surface magnet** increases stiffness with more surface area contact a magnetic pull. However, it also adds significant mass. These factors result in a higher mounted resonance and better high frequency response (at 3dB) than the probe tip method. Curved surface magnets have an effective transmission range under 2000 Hz (120,000 CPM).

It is interesting to note that a stronger magnet, which would decrease stiffness, does not yield significantly better data on most applications since the added mass on the larger magnet counteracts the benefits of the increased stiffness.

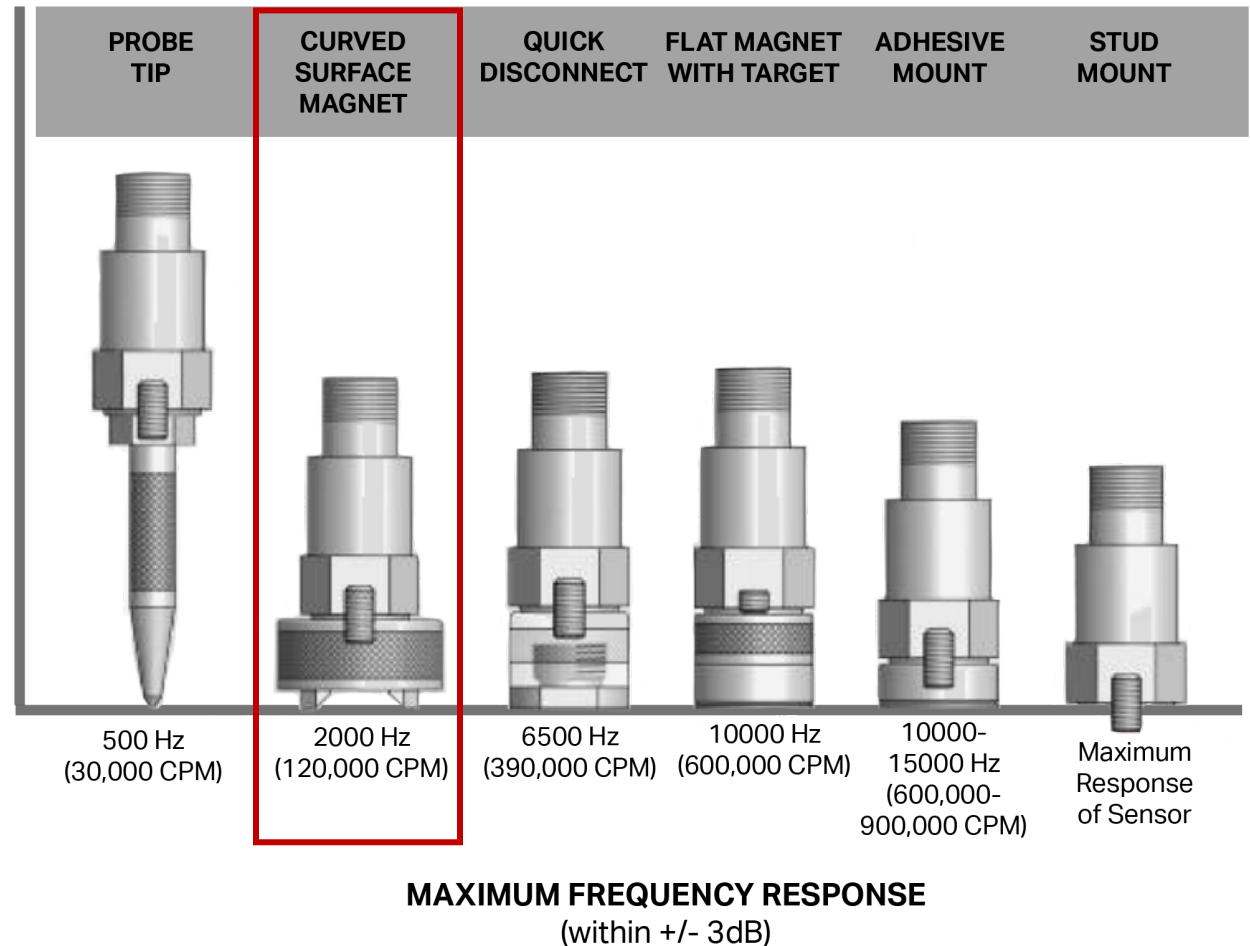

MOUNTED RESONANCE – TYPICAL CHANGES IN RESPONSE

There are a variety of **quick disconnect** systems on the market. The intention of this mounting method is to increase the speed of route collection, and ensure that data is taken from a consistent point.

Depending on the design of the system, some will also increase stiffness when compared to a curved surface magnet, thus raising the mounted resonance and the effective transmission range of the sensor.

CTC's quick disconnect engages five threads with a quarter turn, and provides the best high frequency response in the industry at 6500 Hz (390,000 CPM).

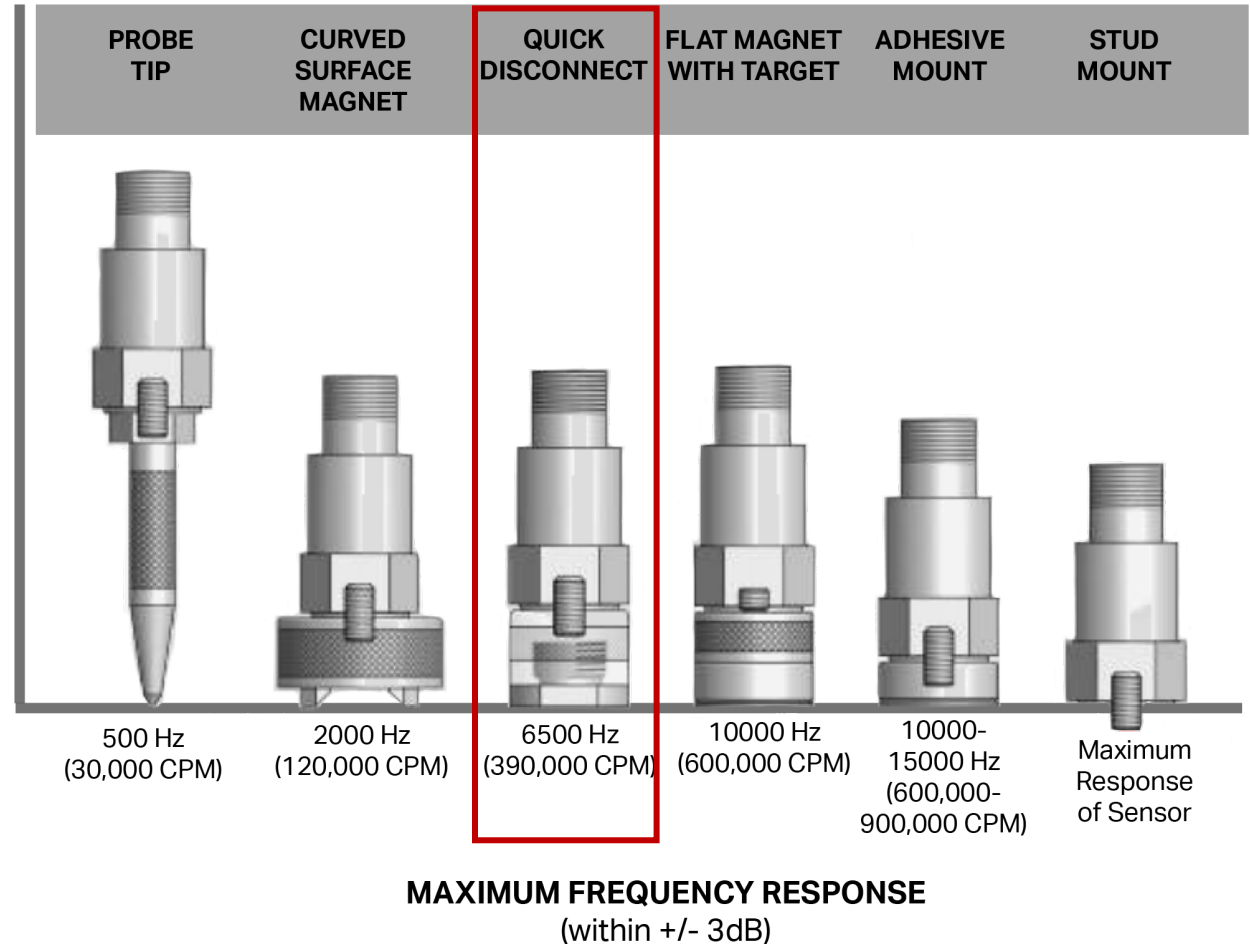

MOUNTED RESONANCE – TYPICAL CHANGES IN RESPONSE

When a **flat magnet** is used on a machined target, surface area contact is maximized and stiffness in general is increased over the other “portable measurement” methods. However, there is still additional mass when compared to the stud mount standard.

Analysts should expect to yield good data up to roughly 7000 – 8000 Hz (420,000 – 480,000 CPM) before hitting 3dB and entering amplification range. However, with perfect installation and execution, some analysts report frequency responses as high as 10000 Hz (600,000 CPM).

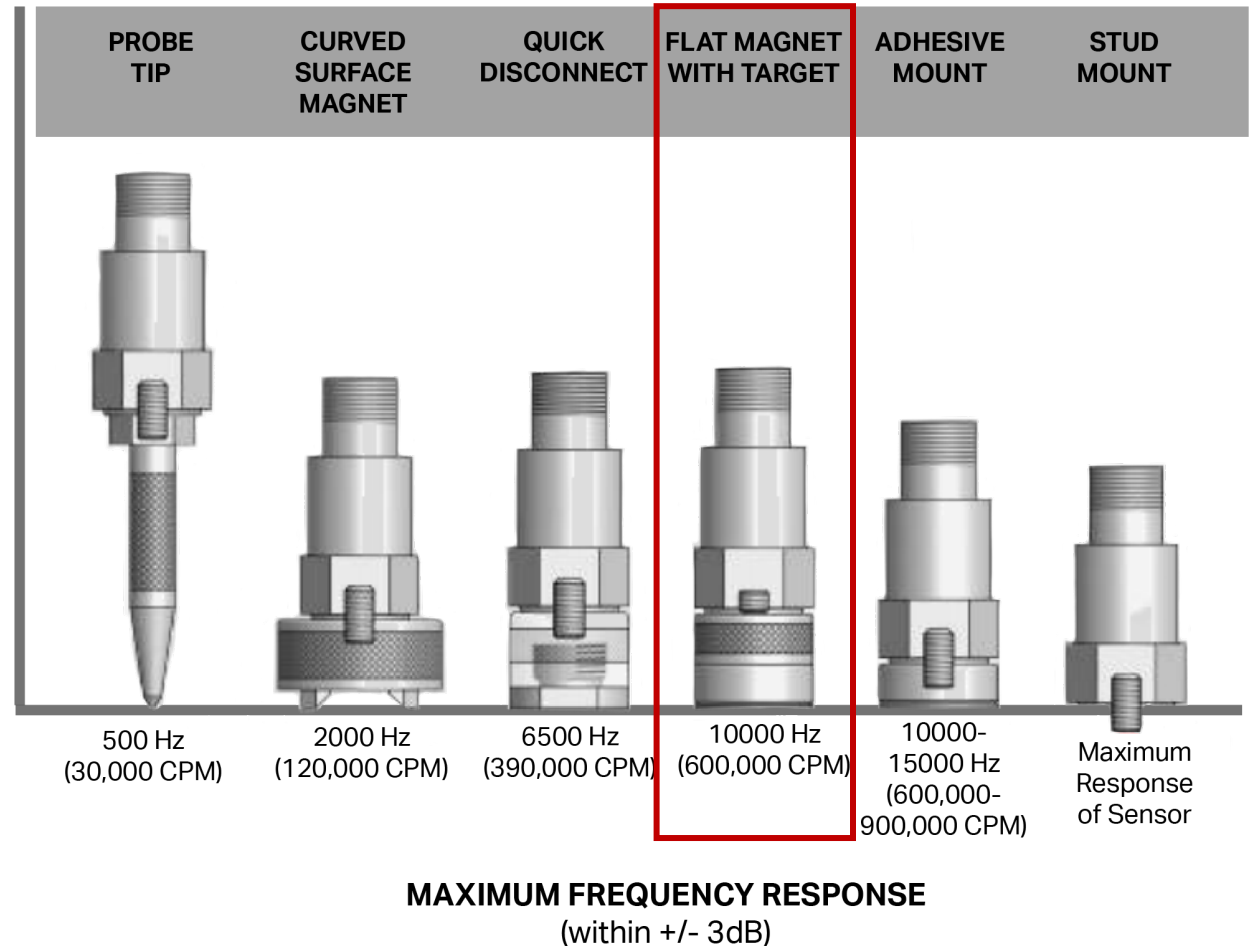

MOUNTED RESONANCE – TYPICAL CHANGES IN RESPONSE

Adhesive mounting is generally for permanent installation and should yield data as high as 10000 to 15000 Hz (600,000 - 900,000 CPM).

In this method, stiffness is maximized and there is only a slight increase in mass compared to stud mounting.

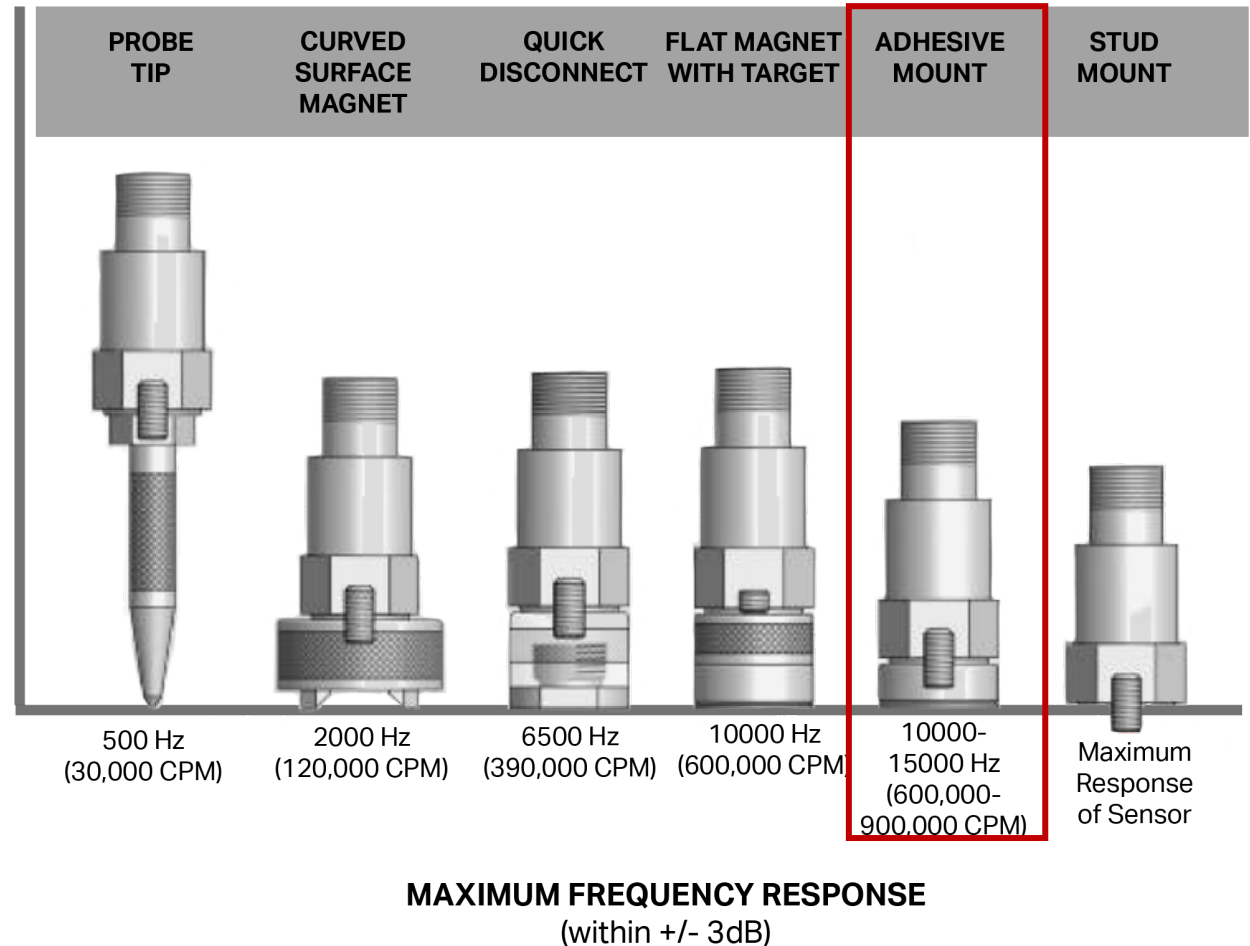

MOUNTED RESONANCE – TYPICAL CHANGES IN RESPONSE

And, of course, the maximum stiffness with the least additional mass is the **stud mount** option. The stud mount option will yield the maximum frequency range of the sensor when properly installed.

Next, let's look at how these various mounting options effect the data collected on an application...

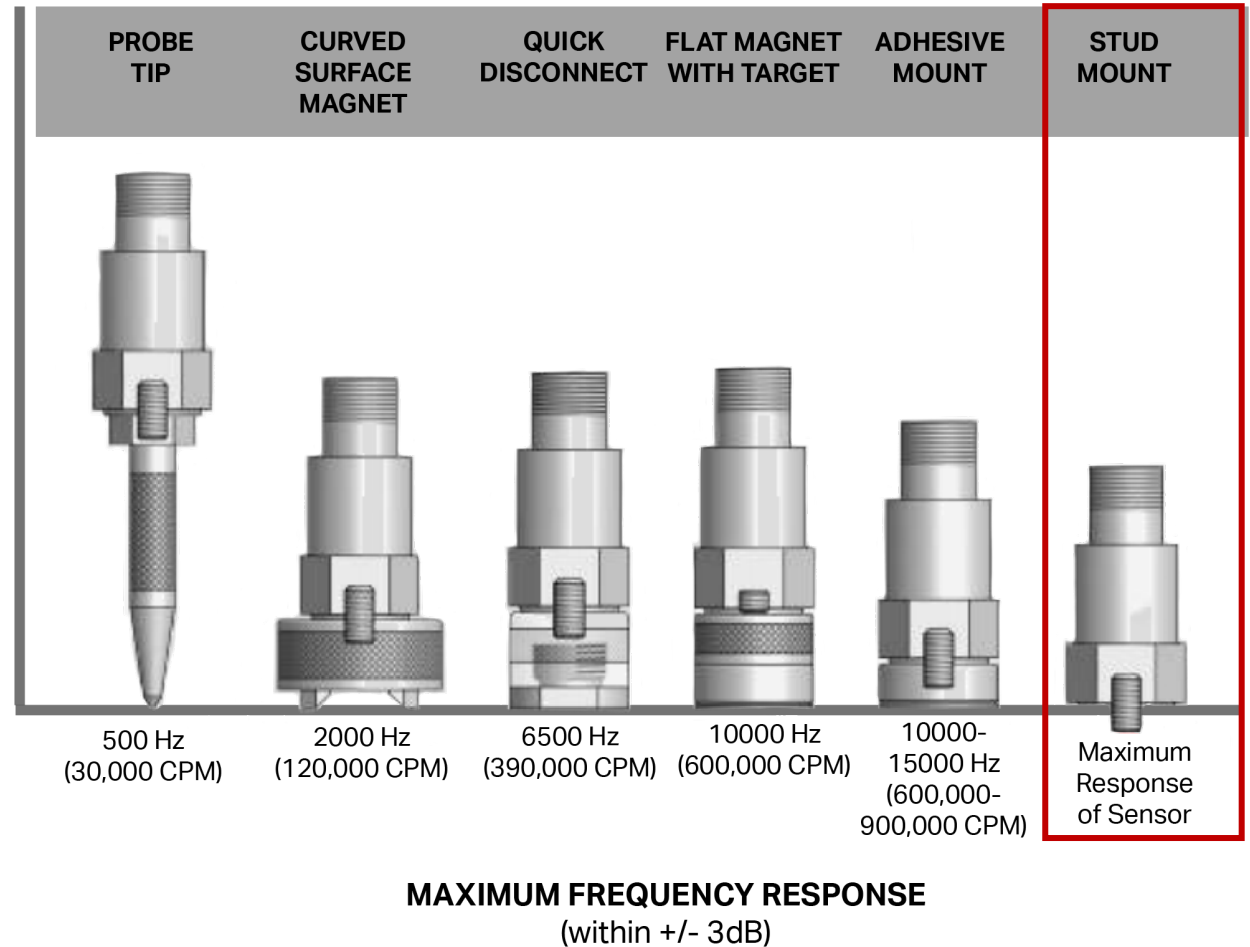

MOUNTED RESONANCE – REDUCED FREQUENCY RESPONSE

Reduced frequency response of a **probe tip** affects amplitudes above 30,000 CPM.

Reduced frequency response of a **curved surface magnet** affects amplitudes above 120,000 CPM.

Flat magnet with target measures all amplitudes less than 600,000 CPM!

Notice how the flat magnet with target method is able to detect faults not seen with the other two methods.

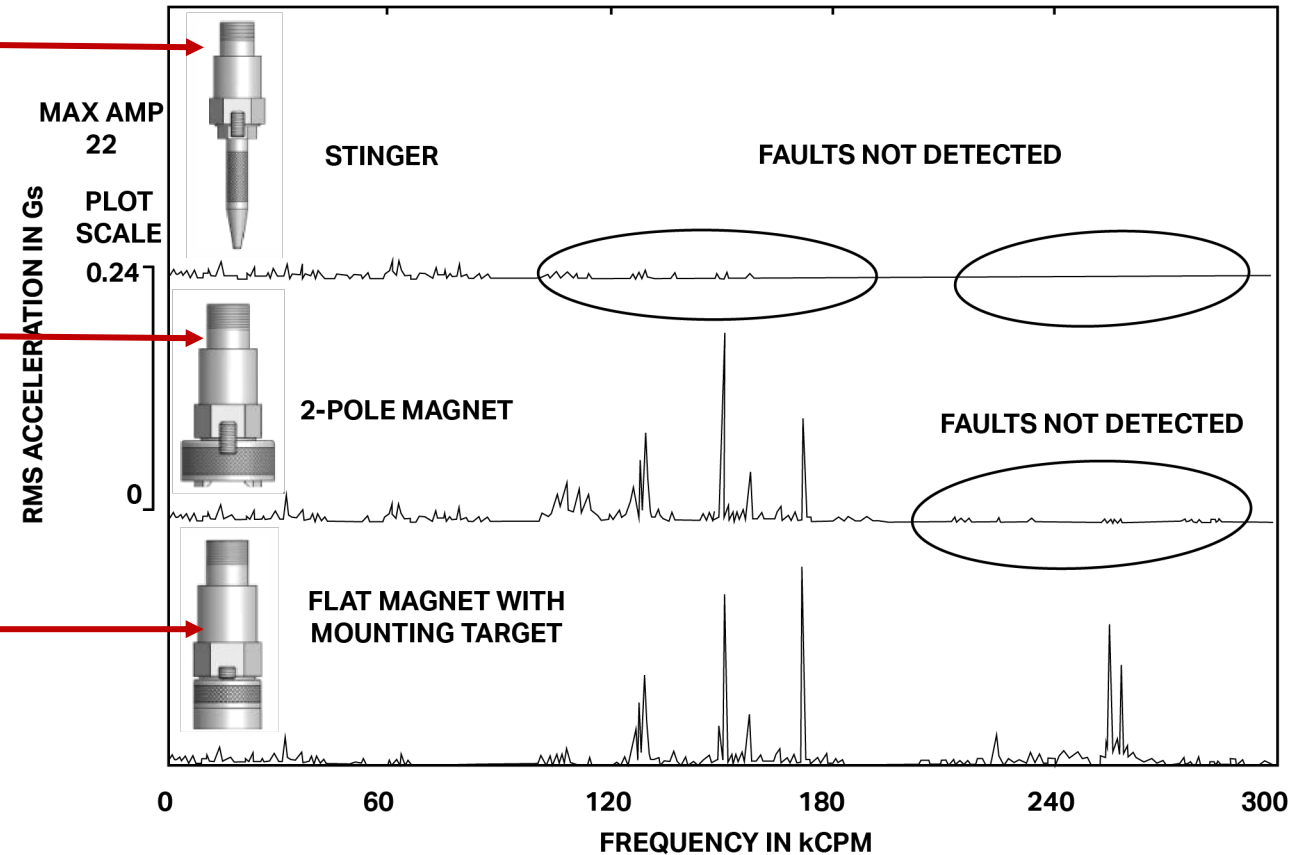

SUMMARY

- ❑ **Consider accelerometer specifications for frequency response when selecting your accelerometer:**
 - ❑ Frequencies above the operating specifications will have increased amplitudes
 - ❑ Frequencies below the operating specifications will have decreased amplitudes
- ❑ **Natural frequency** will depend on the mass and stiffness of the accelerometer and mounting
- ❑ **Resonance** occurs when the frequency of vibration is the same as the natural frequency of the accelerometer
- ❑ **Mounted resonance** is a result of the mounting method used, and can have a direct effect on the natural frequency
- ❑ Choose the accelerometer and mounting method **YOU** need to measure **YOUR** machine frequencies and **avoid resonance**
- ❑ Work within the "transmission" range of the **frequency response**



SUMMARY

Thank you for taking the time to review this training lesson. We hope that you learned something that will help you to collect more accurate and quicker data, to allow you to make better "calls."

CTC prides itself on the industry's best customer service and technical support. Did you know that CTC employs several Vibration Institute Certified **Category 2** and **Category 3** Analysts, and one **Category 4** Analyst who trains for the Vibration Institute? It is all part of our commitment to providing the industry's best service and support.

For more technical information, additional white papers, and training materials, we invite you to visit our website at www.ctconline.com.



SUMMARY

CTC offers a full range of vibration analysis hardware and process and protection instruments for industrial use. Our customers choose us time and time again based on:

- ❑ **Superior durability**
- ❑ **Accuracy and performance**
- ❑ **Quick service (shipping most orders in 3 days)**
- ❑ **Knowledgeable support staff**
- ❑ **Industry's only UNCONDITIONAL LIFETIME WARRANTY
on all CTC Line products**

CONTACT US AT SALES@CTCONLINE.COM | WWW.CTCONLINE.COM

