

VIBRATION MONITORING
FOR THE
Mining
INDUSTRY



**WHEN RELIABILITY MATTERS
CONNECT TO CONFIDENCE**



Critical mining assets often run 24/7 under harsh environmental conditions. As a result, machine failure can represent a huge risk to both operational uptime and human safety. Industrial vibration monitoring can be applied to integral components of large mining equipment, including motors, generators, gearboxes, pumps, and fans to detect common faults. Predictive maintenance can help detect wear and tear prior to machine failure in order to minimize production loss at a mine site by providing time to source parts and schedule an outage.

Predictive Maintenance for Rolling Element Bearings

CTC accelerometers can be used to monitor and detect common faults in rolling element bearings and gears. Common faults that can be detected include unbalance, misalignment, blade pass, and vane pass.

What We Offer

Accelerometers

CTC accelerometers can be used to monitor rolling element bearings for mining machinery. We suggest our standard 100 mV/g accelerometers. We also offer 500 mV/g accelerometers for low frequency applications with better signal to noise ratio and dual output sensors to combine vibration and temperature measurements in one hermetically sealed package. These accelerometers are available in top or side exit connector configurations as well as integral cable and armored integral cable options. In harsh mining environments where falling debris, dust, and dirt are common, integral cable sensors eliminate connector durability concerns. Integral armor cable sensors provide an additional level of durability for the harshest environments and are commonly used in conveyor applications where conductive dust and sediment can penetrate and disrupt continuity in a standard cable and connector combination.

Since many mining applications have hazardous environments due to gas, oil, or dust that could create a combustible atmosphere in and around the machines, CTC offers hazardous rated sensors by certifying organizations including:



United States of America and Canada



Atex, (ATmospheres EXplosible)
European Directorate



International Electrochemical
Commission in Explosive Atmospheres

Mounting hardware, cables, & connectors

CTC offers the necessary mounting hardware, cables, and connectors for all applications.

Suggested Product Pairings

Sensor	Cable	Connector	Mounting Hardware
Standard Accelerometers	CB111 with yellow teflon jacket or CB206 with red teflon and a stainless steel armor jacket	A2A, A2N, D3Q, or J2Q with Silicone sealing Ring and stainless steel locking collar B2A, B2N with seal tight boot for vacuum tight seal	Quick Disconnect Adhesive mounting pad Stud mounting Zerk adaptor Fin Mount
Dual Output Sensors	CB112 with white teflon jacket	A3A, A3N, D3Q, J2Q, or J4Q with Silicone sealing Ring and stainless steel locking collar B3A or B3N with seal tight boot for vacuum tight seal	Sensor Protector

Cable & Connector Sets for Harsh Environments

The V2N and V3N connectors feature IP68 sealing for those really tough environments where it is necessary to use a connector, but eliminate any type of water or dust contamination to the sensor and connector interface. Both the V2N (two socket) and V3N (three socket) connectors feature Viton seal tight boots with internal threads for maximum grip sealing of the sensor interface. The internal components are molded from Nylon to the Teflon jacketed cables to maximize durability and create a connected rated to 250 °F (121 °C). CB111 yellow jacketed Teflon cable is used with the V2N and CB119 orange jacketed Teflon cable is used with the V3N.



Junction Boxes

Junction boxes can be used for local measurements or the transmission of data to online vibration monitoring systems. Junction boxes can be used for cable reduction purposes or for switched outputs during manual route data collection of the vibration signals. All junction boxes are available in fiberglass or stainless steel and feature well organized sensor management and measurement access in a NEMA 4X enclosure. Our sloped top junction boxes are engineered specifically for the mining industry to prevent dust and dirt build up on top of the box that could contaminate internal components.

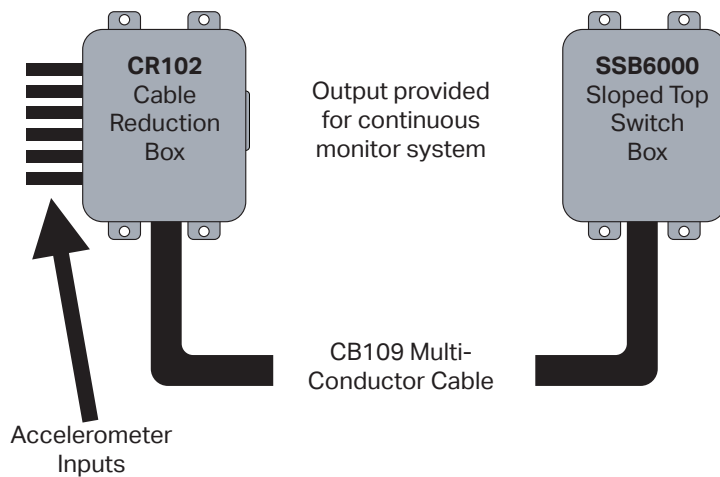

Suggested Junction Boxes



Predictive Maintenance for Fluid Film Bearings

Many large motors, generators, and gear boxes will incorporate fluid film bearings to support their rotating shafts. These shafts require monitoring, which can be done through the use of X and Y radial proximity probes. CTC's PRO line proximity probes are non-contact eddy current sensors that measure the vibration of the shaft relative to the case of the machine, and the location (gap) of the shaft in the bearing. PRO proximity probes can be mounted externally to the bearing using threaded or clamping probe brackets.

Suggested PRO Products

Proximity Probes

We are proud to offer API Standard 670 and Bently compatible Proximity Probes available in:

- Multiple case and thread lengths available
- 8 mm probe tip diameter with 3/8-24 or M10x1 threaded body
- 5 & 9 Meter System lengths



**STANDARD
MOUNT**



**ARMORED
MOUNT**



**REVERSE
MOUNT**



DRIVER

Driver Enclosures

Driver enclosures allow you to protect up to six proximity probe drivers from dirt, dust, oil and water

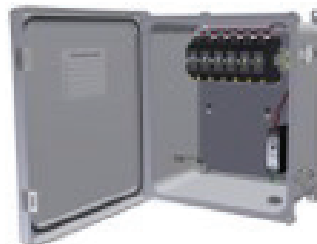

Mounting hardware

Proximity probes are designed to be mounted on fluid film bearings using PRO Proximity Probe Mounts. It is important that they are mounted correctly to provide the most accurate measurements



MOUNTING BUSHINGS

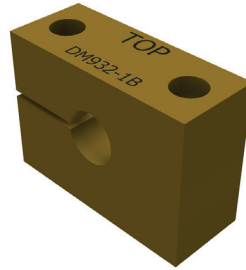

**CLAMPING
BLOCKS**



**NON-CLAMPING
BLOCKS**

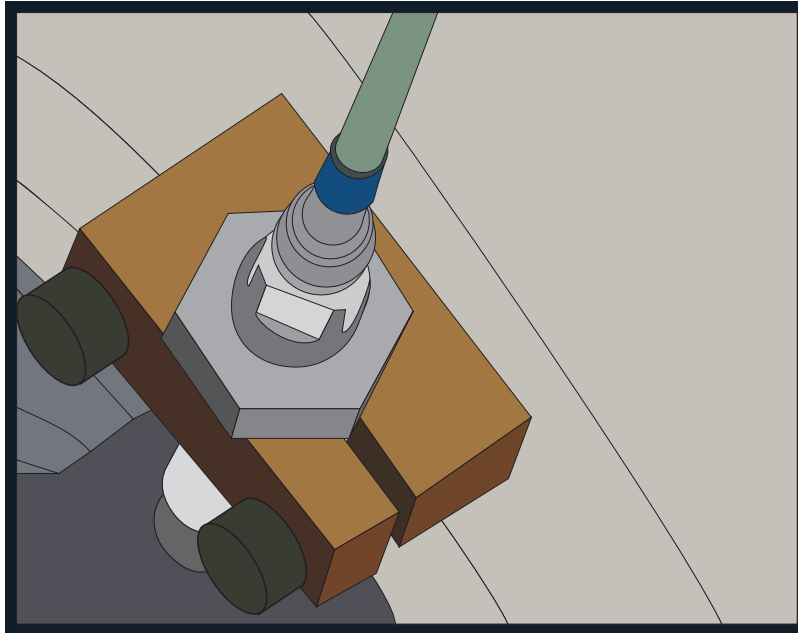

CTC is the world leader in the design and manufacture of industrial accelerometers, piezo velocity transducers, 4-20 mA vibration sensors, and proximity probes as well as all related mounting hardware, cabling, and junction boxes. Our products enable efficient vibration monitoring for predictive maintenance in a wide variety of industries. Industries served include cement, mining, petrochemical, food & beverage, auto, steel, wind, paper & pulp, power generation, water & wastewater treatment, pharmaceutical, hospitals, bottling, and more. Our mission is to offer the widest variety of accelerometers and vibration hardware products, which are compatible with data collectors and online monitoring systems, as well as the tools for installation.



The CTC product line features vibration analysis hardware for heavy industry.

All CTC products are backed by our unconditional, lifetime warranty. If any CTC product should ever fail, we will repair or replace it at no charge.



The PRO line offers 4-20mA vibration monitoring solutions and proximity probes.

All PRO products are backed by a lifetime warranty on materials and workmanship. PRO will repair or replace any of our products as long as the product was not subjected to misuse, neglect, natural disasters, improper installation, or modification.

All stock products qualify for a full refund if returned in new condition within 90 days of shipment. Build to order products qualify for a 50% refund if returned in new condition within 90 days of shipment. Custom products are quoted and built specifically to the requirements of the customer, which may include completely custom product designs or private labeled versions of standard products for OEM customers. Custom products ordered are non-cancellable, non-returnable and non-refundable.

