

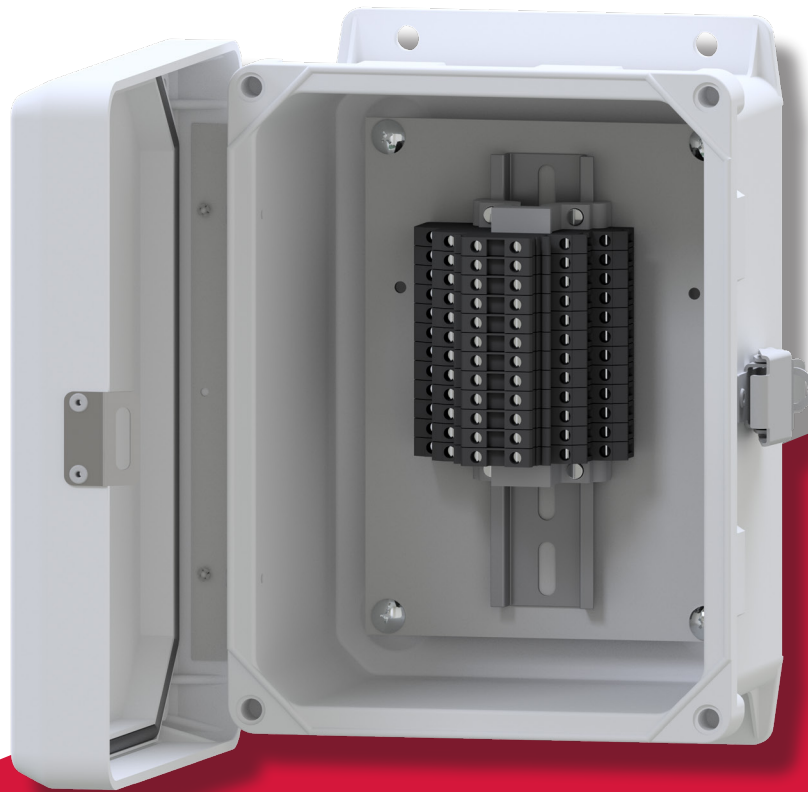

VIBRATION ANALYSIS HARDWARE



**CRHT102 Series Cable Reduction Box
8-16 Channel
Product Manual**

TABLE OF CONTENTS

- Introduction.....3
- Product Description.....3
- Product Dimensions & Diagram.....4
- Mounting Instructions.....5
- Conduit Entry6
- Grounding.....7
- Installation of Sensor / Signal Input Cable.....7
- Post Installation Testing 10
- Warranty & Return Information 12



INTRODUCTION

CTC cable reduction box solutions offer a reliable and economic means of consolidating up to 16 vibration channels into one multi-conductor cable.

CRHT102 Series Cable Reduction Box Overview: 8-16 channel boxes, fiberglass enclosure

Consolidating 16 cables to one single multi-conductor cable significantly reduces the cost of installation, as running one multi-conductor cable in place of 16 individual cables is much faster and more economical to install.

Input wiring from each sensor is connected to the box via terminal blocks. Each terminal block includes three inputs –positive, common and shield, the corresponding output terminal blocks are marked within the enclosure and also feature three connection inputs – positive, common and shield. Multi-conductor cabling with 8, 12 or 16 paired wires is connected to each output terminal block inside the enclosure. The cable exits through the bottom of the box as one single multi-conductor cable to provide input to a vibration switch box or online system for data collection.

Rated for NEMA 4X (IP66), the CRHT102 can withstand harsh environments including temperatures ranging from -40 to 212 °F (-40 to 100 °C). The box is also resistant to hose directed fluid and corrosion. A snap latch is installed on the door allowing the box to be sealed from the elements when not in use.



PRODUCT DIMENSIONS

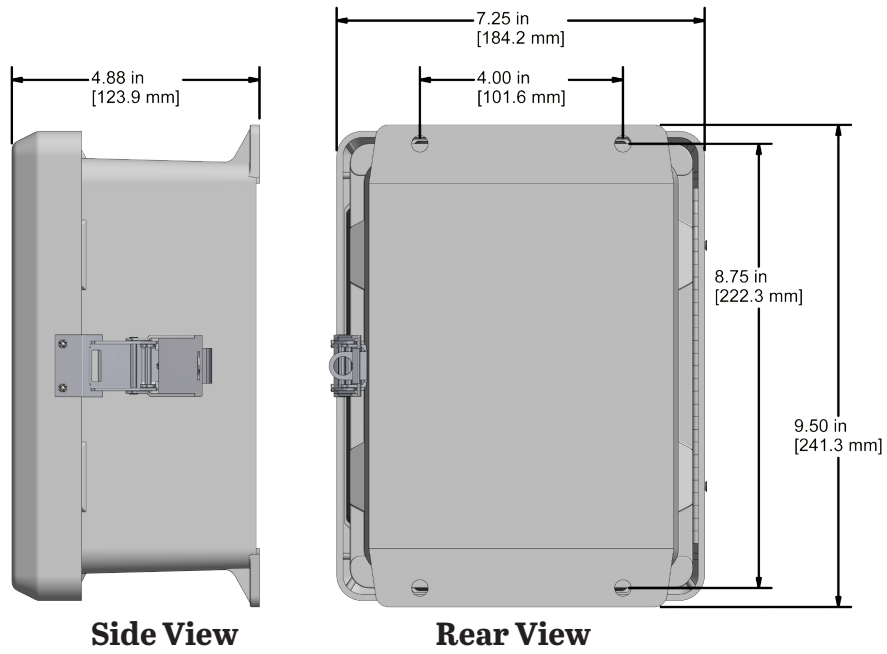

Figure 1. Dimensions

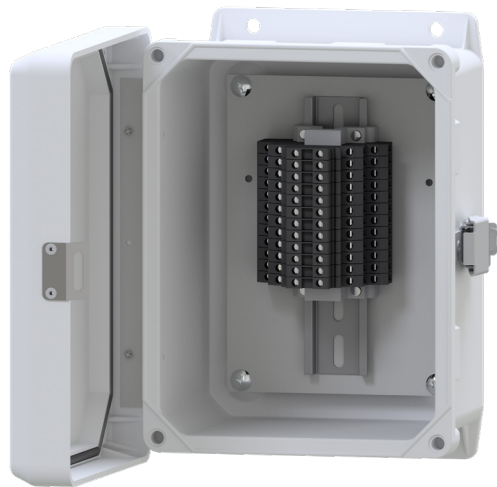

Figure 2. Diagram

MOUNTING INSTRUCTIONS

Note: if you have purchased a cable reduction box without cable entries provided, you should add your own entry prior to mounting the cable reduction box. CTC does not recommend drilling holes in the top of the cable reduction boxes due to access and moisture concerns.

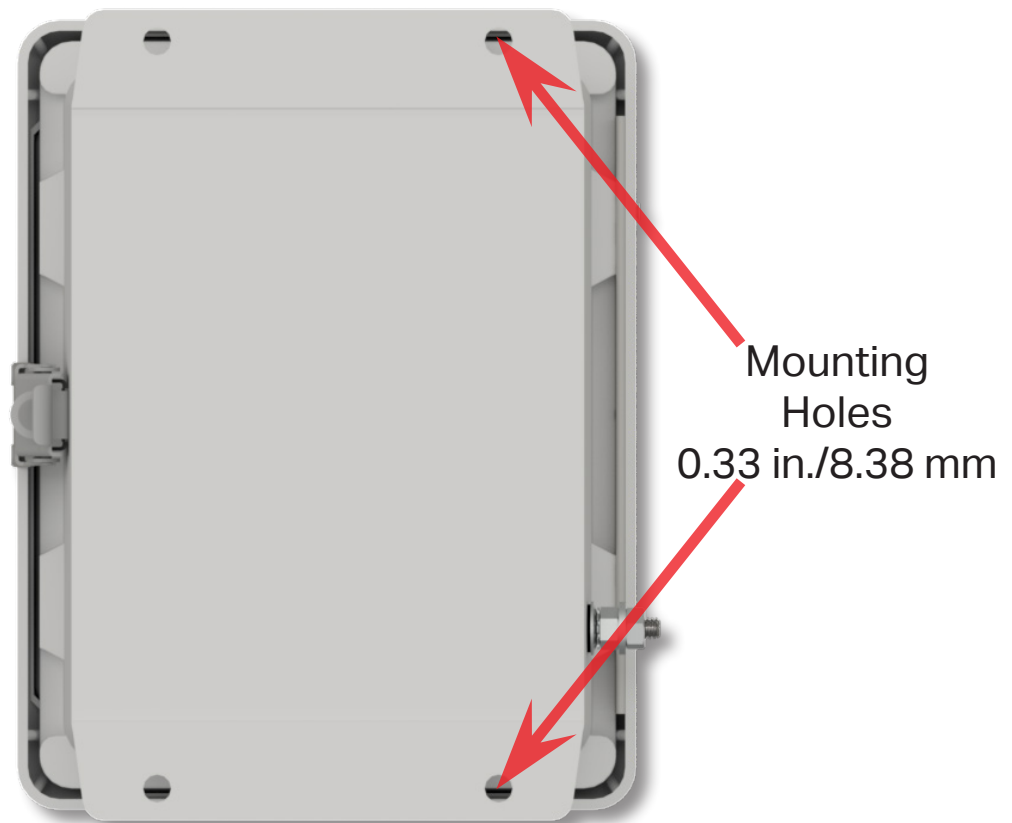

Figure 3. Cable Reduction Box Rear View

CONDUIT ENTRY

If you are running conduit to your enclosure, ensure the conduit cable entry enters from the bottom of the enclosure when mounted.

Note: To ensure moisture will not flow into the enclosure, a hole should be drilled at the lowest point in the conduit to provide drainage for any moisture.

Correct

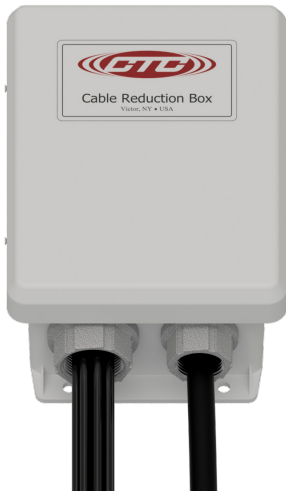

Incorrect



Figure 4. Conduit Entry for Switch Box

GROUNDING

In order to avoid potential ground loop problems, the CRHT102 series is not grounded. All cabling, including the shield drain, should be passed through to the final termination point.

SENSOR INSTALLATION

Installation of sensors/signal input cable

1. Feed blunt end through the cable entry at the bottom of the enclosure.

Note: it is recommended that cables are marked on both ends.

For cord grip cable entry, take off the cord grip cover with bushing and run cable into enclosure, hand tighten cord grip cover to base to prevent damage to cord grip.



Figure 7. Cord Grip Entry

1. Strip outer jacket of cable back 1¼ in. and remove all of the shielding.
2. Separate the internal wires from the shield and twist the shield.
3. Strip red and black insulation back ¼ in.



Figure 8. Stripped Wire

4. While viewing the rear of the panel, locate the appropriate channel. Using a mini flathead screwdriver, loosen the screws for the channel and insert the wires into the termination block. Orientation is as follows:
 - a. Red insulated conductor wire is connected to (+).
 - b. Black insulated conductor wire is connected to (-).
 - c. Shield drain wire is connected to ground (GND).
 - d. Tighten the screw on each wire to hold it in place.

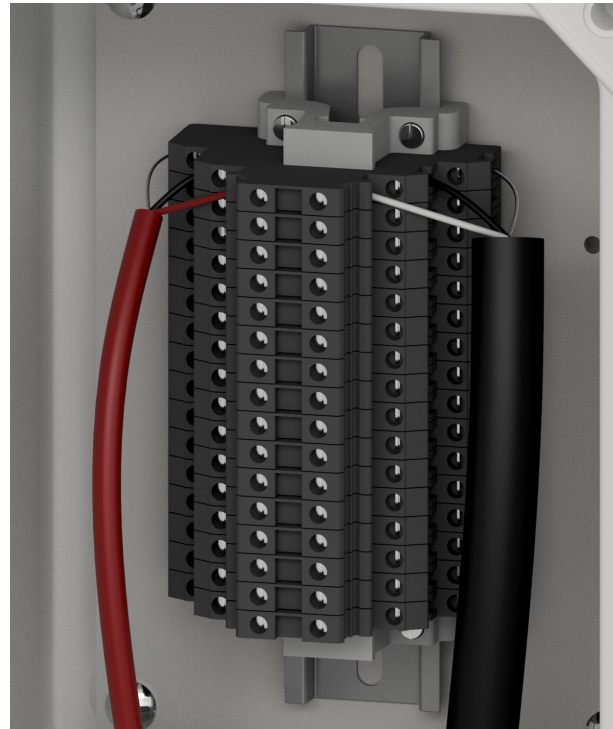
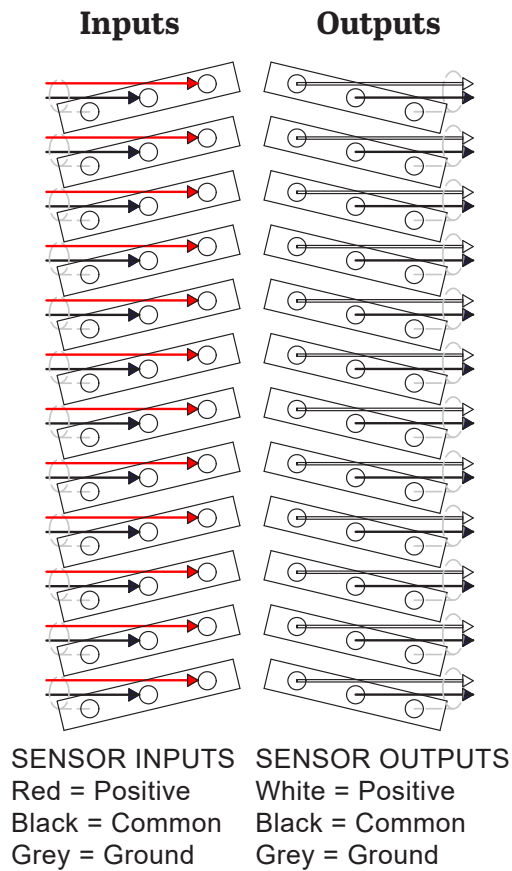

Figure 9. Connecting Cables to Switch Box

5. Tighten the screws on the termination block and double check to ensure that the cable is going to the correct channel.

POST INSTALLATION TESTING

The TM1018 Accelerometer Verification Meter can be used to verify cable conductivity, sensor location and proper wiring connections. The Verification Meter will indicate if the sensor, cable and/or junction box is in working condition. It will also confirm bias voltage of the accelerometer, which will inform you of the operation of the internal accelerometer amplifier.

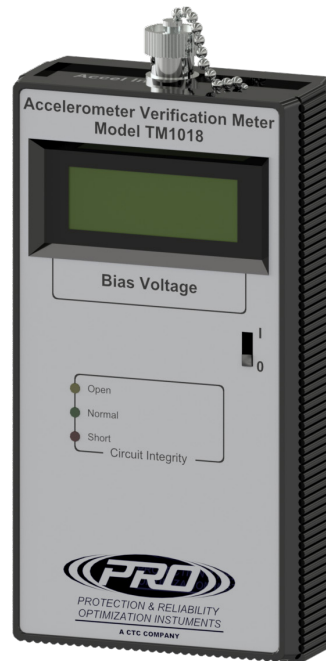

Figure 10. TM1018 Accelerometer Verification Meter

Testing Method:

1. Utilizing two personnel, Person A will be located at the cable reduction box, while Person B will be located at the measurement location.
2. Once positioned, Person A will connect the TM1018 to the data collector output to the cable reduction box using CTC part number CB103-C47-003-F (included in the TM1018 testing kit). Person A should observe a "NORMAL" LED reading.
3. Person B disconnects the cable from the accelerometer, and the TM1018 should respond with an "OPEN" LED. Reconnect the cable to the accelerometer, and the TM1018 should respond with a "NORMAL" LED.
4. Repeat for each measurement location to verify that accelerometer location is properly identified at the cable reduction box.

The following LED Readout indicates the circuit integrity:

1. Green LED: Normal. Indicates proper connection and an output bias will be given, indicating the health of the sensor (4 – 16 V indicates a healthy accelerometer).
2. Yellow LED: Open Circuit. Indicates one of the following:
 - a. Cable connector is not connected to accelerometer.
 - b. Cable is open circuit (broken or not connected @ one end).
 - c. Accelerometer is not functioning correctly
3. Red LED: Short Circuit. Indicates one of the following:
 - a. Water or contamination in the connector.
 - b. Reverse Wiring ((+) and (-) leads are reversed).
 - c. Wires in cable reduction box or cable connector (+) & (-) are touching.



WARRANTY & REFUND

Warranty

All CTC products are backed by our unconditional lifetime warranty. If any CTC product should ever fail, we will repair or replace it at no charge.

Refund

All stock products qualify for a full refund if returned in new condition within 90 days of shipment. Build to order products qualify for a 50% refund if returned in new condition within 90 days of shipment. Custom products are quoted and built specifically to the requirements of the customer, which may include completely custom product designs or private labeled versions of standard products for OEM customers. Custom products ordered are non-cancellable, non-returnable and non-refundable.

