

CTC AppNotes

A series of technical documents written by members of the CTC community

Executive Summary

M12 connectors have been a standard connector for many types of industrial instrumentation, especially in Europe. Typically, M12 Connectors are used in sensor buses and field buses, and are in some cases replacing MIL-5015 2 pin connectors, and are sometimes more readily available at a lower cost due to the large number of applications outside of the vibration industry.

M12 connectors

M12 connections are very common in process and instrumentation fields, especially in Europe. The general acceptance of these connectors in sensors buses and field buses, as well as the general availability of those type of connectors,



CTC's AC104 Side exit sensor with M12 four pin connector. "AC104-M12A"

has raised questions of whether or not to offer a sensor that has that M12 connection. Based on the increasing number of customer requests for sensors with an M12 connector, and the fact that there are some vibration sensors that currently require changing and/or retrofitting, CTC has released some of our most popular sensors with a 4 Pin M12 connector.

Now available are top and side exit 100 mV/g sensors, AC102-M12A and AC104-M12A; and

AC135-M12A

4 Pin Connector

Connector Pin	Polarity
1	(+) Signal / Power
2	(-) Common

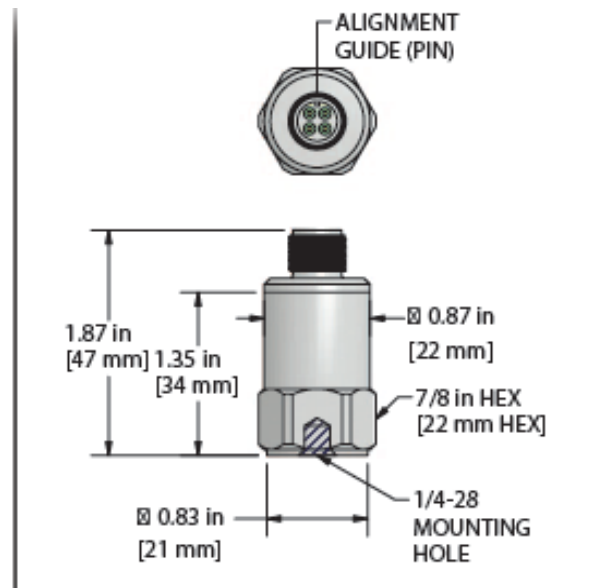

AC135-M12A schematic drawing.

the top and side exit 500 mV/g sensors AC135-M12A and AC136-M12A.

CTC also offers a factory installed connector (C502) to mate with these sensors, and field installable connectors are available upon request.



Field installable M12 connector

If you have any questions or for further information please contact CTC directly via Email at dgripe@ctconline.com or jsmith@ctconline.com or feel free to call 1-800-999-5290 in the US and Canada or +1-585-924-5900 internationally.

**

If any CTC vibration analysis hardware product should ever fail, we will repair or replace it at no charge.



**