

4-20 mA

VIBRATION MONITORING

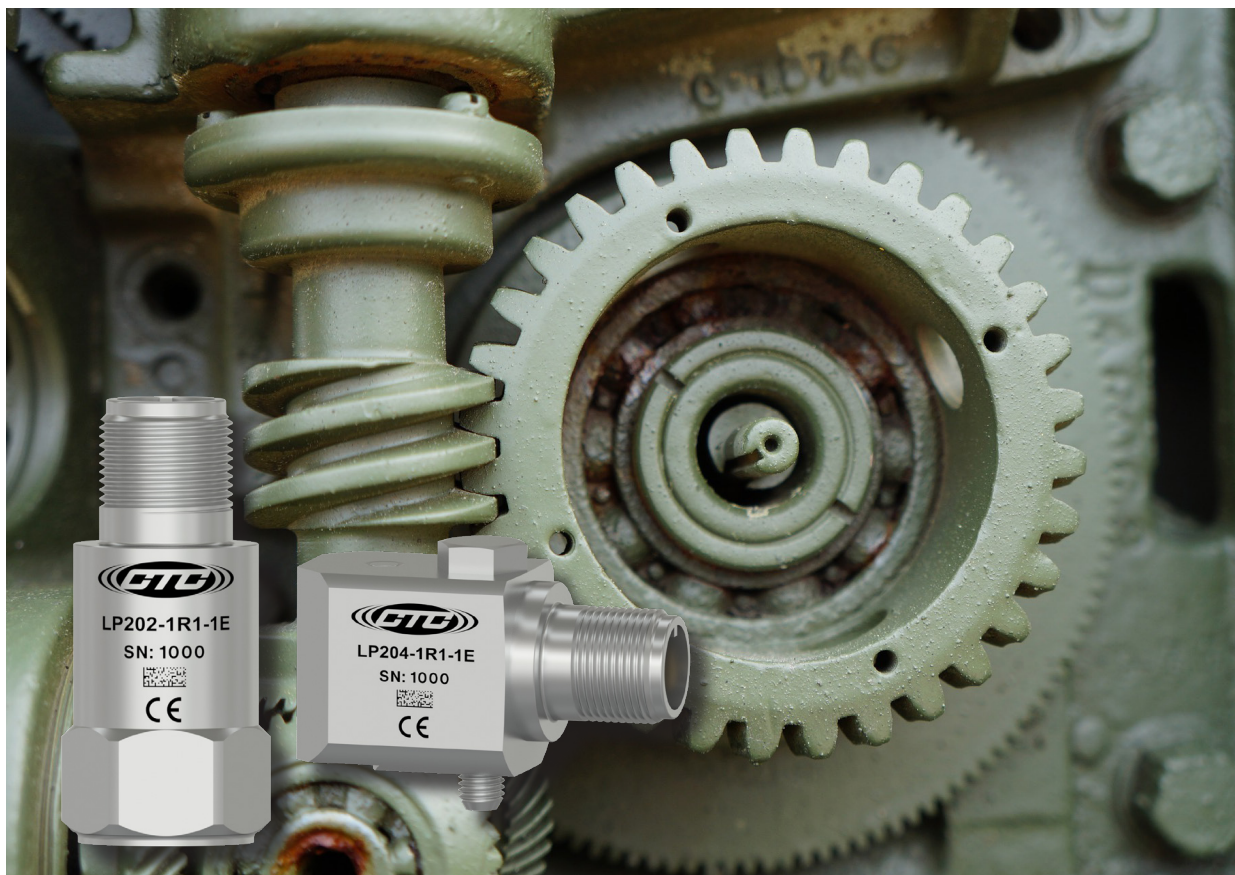

**WHEN RELIABILITY MATTERS
CONNECT TO CONFIDENCE**

4-20 mA technology can be used to measure temperature, pressure, flow, and speed as well as the overall vibration of rotating machines. Adding a vibration sensor/transmitter to the machine provides a critical measure of the machine's health, and can be used to identify changes in balance, alignment, gears, bearings, and many other potential faults.

How it Works

The purpose of the 4-20 mA analog current loop is to transmit the signal from an analog vibration sensor over a distance in the form of a 4-20 mA current signal. The current signal generated is proportional to the overall vibration of the equipment or machinery that is being monitored. This output current has a range of 4-20 mA, with 4 representing the minimum and 20 representing maximum amplitudes (within the range of 4-20 mA). The 4-20 mA signal output is proportional to the defined amplitude generated within a specified frequency band. Therefore, the signal does not include data from frequencies outside the frequency band, but includes all vibration (critical and non-critical faults) within that band.

What We Offer

CTC offers a wide array of 4-20 mA output solutions for industrial applications. CTC's standard 4-20 mA loop powered vibration sensors are available with velocity or acceleration, alongside temperature output measurements options. CTC's loop powered sensor line also includes a dual output option, with both 4-20 mA output and dynamic output configurations in one sensor. Other options include 24 Volt DC powered transmitters that power standard IEPE accelerometers and convert the vibration to a powered 4-20 mA signal. These transmitters also offer a 4-20 mA output for temperature when coupled with CTC dual output vibration and temperature sensors.

LP200 and LP300 Series

A loop power vibration sensor/transmitter like the LP200 Series (4-20 mA proportional to vibration measured in velocity) or the LP300 Series (4-20 mA proportional to vibration measured in acceleration) can be mounted on the machine and added to the control loop. As the overall vibration of the machine changes, the 4-20 mA output will vary proportionally.

Only two wires are required to supply power to the sensor and send the current signal. A loop supply voltage is used to power the remote sensor. A series resistor R_L at the loop power supply converts this current to a voltage that can be used by the process monitor/controller to record or distribute the parameter being measured.



4-20 mA Loop Power Sensor

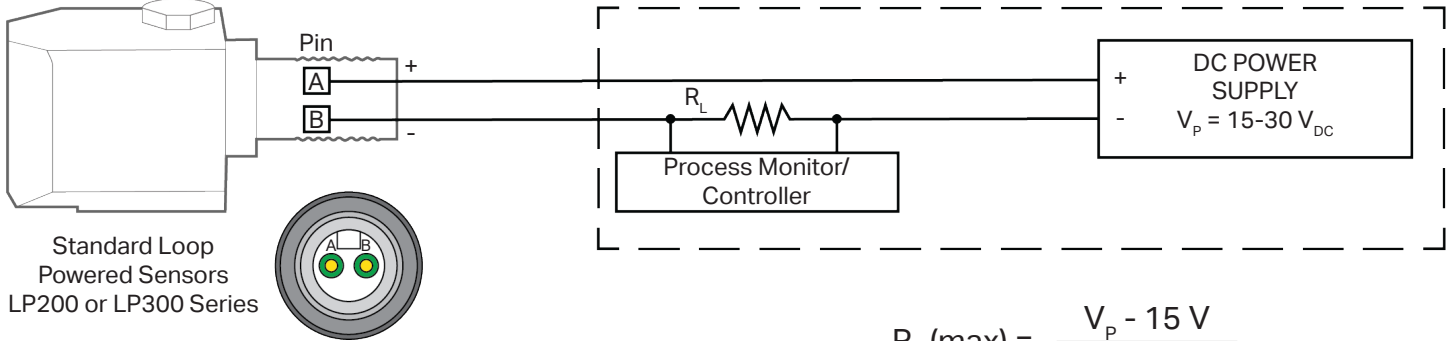

$$R_L (\text{max}) = \frac{V_P - 15 \text{ V}}{0.020 \text{ A}}$$

LP200 & LP300 Series

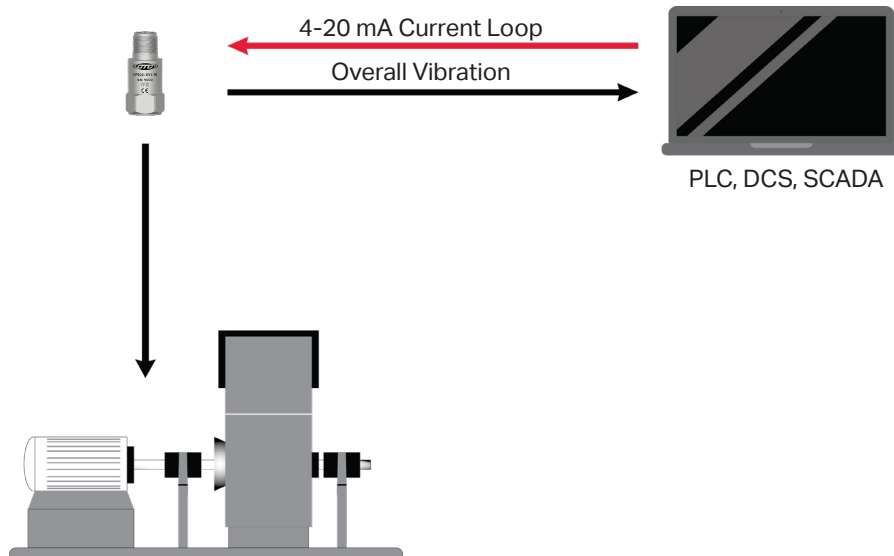

DUAL OUTPUT LP23X AND LP33X SERIES

Dual output LP262 and LP362 Series sensors contain an integrated circuit to measure the temperature inside the sensor case. The temperature output is monitored in the form of $mV_{DC}/^{\circ}C$ using a voltmeter across pins C & B of the sensor when the circuit is powered by the 4-20 mA loop at pins A & B. The DC voltage output is proportional to temperature from $-40^{\circ}C$ ($0.10 V_{DC}$) to $+100^{\circ}C$ ($1.35 V_{DC}$) or $-40^{\circ}F$ ($0.10 V_{DC}$) to $+212^{\circ}F$ ($1.35 V_{DC}$). This output can be trended in voltage to monitor the change in temperature of the machine.



HAZARDOUS RATED SENSORS

CTC offers the intrinsically safe LP800 and LP900 series of sensors for hazardous locations.



Signal conditioners can be used in conjunction with standard dynamic accelerometers, piezo velocity sensors, or displacement probes. The signal conditioner accepts the dynamic input and converts it to a proportional 4-20 mA output for the PLC system, DCS or SCADA system. The signal conditioner can be adjusted in the field so that the scaling and filters match your application. The dynamic vibration signal is available from a standard BNC connection on the front of the signal conditioner, or as an optional output from the terminal block.

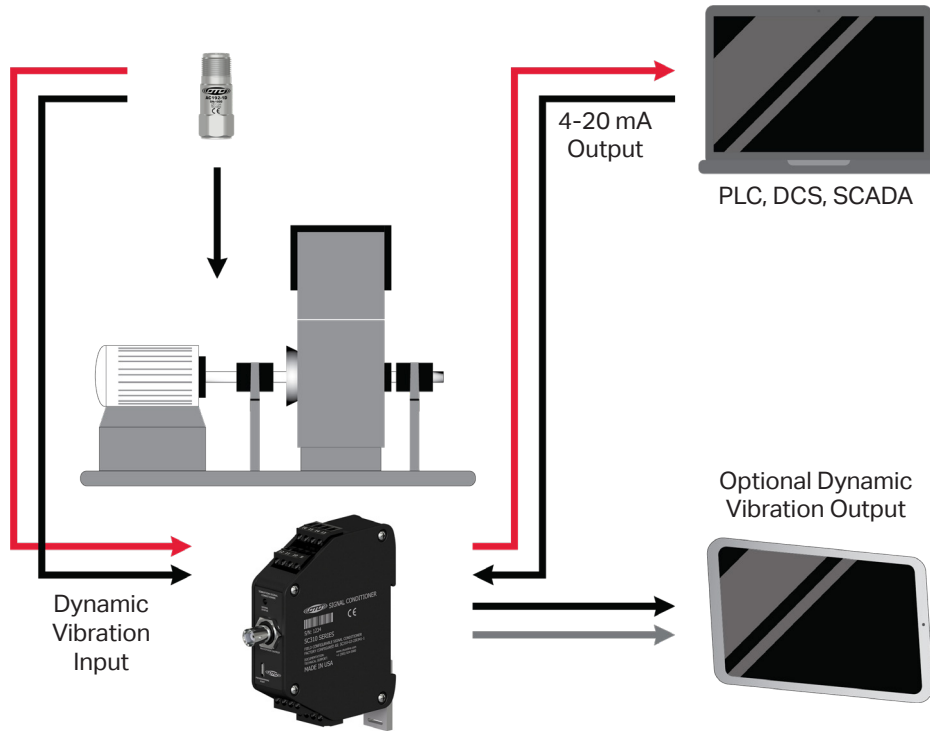

Signal Conditioner Provides Selectable Adjustments of all Scales and Ranges

The signal conditioner is also compatible with the TA202, TA204, TA231, TA233, and TA284 series dual output vibration and temperature sensors. The signal conditioner in combination with any of these sensors will provide one 4-20 mA output proportional to vibration, and a second 4-20 mA output proportional to temperature.

CTC is the world leader in the design and manufacture of industrial accelerometers, piezo velocity transducers, 4-20 mA vibration sensors, and proximity probes as well as all related mounting hardware, cabling, and junction boxes. Our products enable efficient vibration monitoring for predictive maintenance in a wide variety of industries. Industries served include cement, mining, petrochemical, food & beverage, auto, steel, wind, paper & pulp, power generation, water & wastewater treatment, pharmaceutical, hospitals, bottling, and more. Our mission is to offer the widest variety of accelerometers and vibration hardware products, which are compatible with data collectors and online monitoring systems, as well as the tools for installation.



The CTC product line features vibration analysis hardware for heavy industry.

All CTC products are backed by our unconditional, lifetime warranty. If any CTC product should ever fail, we will repair or replace it at no charge.



The PRO line offers the industry's most reliable proximity probe sets.

All PRO products are backed by a lifetime warranty on materials and workmanship. PRO will repair or replace any of our products as long as the product was not subjected to misuse, neglect, natural disasters, improper installation, or modification.

**Please note: The logo on the product indicates the specific warranty for which it will qualify for the duration of its lifetime.*

All stock products may be returned for a 25% restocking fee if returned in new and unused condition within 90 days of shipment. Built-to-order and private-label products qualify for a 50% refund if returned in new and unused condition within 90 days of shipment. Custom products are quoted and built specifically to the requirements of the customer, which may include completely custom product design or private-labeled versions of standard products for OEM customers. Custom products are non-cancellable, non-returnable, and non-refundable.

